

promoting access to White Rose research papers



Universities of Leeds, Sheffield and York
<http://eprints.whiterose.ac.uk/>

This is an author produced version of a paper published in **Wear**.

White Rose Research Online URL for this paper:

<http://eprints.whiterose.ac.uk/3521/>

Published paper

Lewis, R., Barber, S.C. and Dwyer-Joyce, R.S. (2007) *Particle motion and stain removal during simulated abrasive tooth cleaning*, *Wear*, Volume 263 (1-6), 188 - 197.

**PARTICLE MOTION AND STAIN REMOVAL DURING SIMULATED
ABRASIVE TOOTH CLEANING**

R. LEWIS*, S.C. BARBER, R.S. DWYER-JOYCE

Department of Mechanical Engineering, The University of Sheffield, Mappin Street,
Sheffield, S1 3JD

*Corresponding author: Tel. +44 (0) 114 2227838; Fax. +44 (0) 114 2227890

roger.lewis@sheffield.ac.uk

ABSTRACT

Stain removal from teeth is important both to prevent decay and for appearance. This is usually achieved using a filament based toothbrush with a toothpaste consisting of abrasive particles in a carrier fluid. This work has been carried out to examine how these abrasive particles interact with the filaments and cause material removal from a stain layer on the surface of a tooth. It is important to understand this mechanism as while maximum cleaning efficiency is required, this must not be accompanied by damage to the enamel or dentine substrate.

In this work simple abrasive scratch tests were used to investigate stain removal mechanism of two abrasive particles commonly used in tooth cleaning, silica and perlite. Silica particles are granular in shape and very different to perlite particles, which are flat and have thicknesses many times smaller than their width.

Initially visualisation studies were carried out with perlite particles to study how they are entrained into a filament/counterface contact. Results were compared with previous studies using silica. Reciprocating scratch tests were then run to study how many filaments have a particle trapped at one moment and are involved in the cleaning process. Stain removal tests were then carried out in a similar manner to establish cleaning rates with the two particle types. Perlite particles were found to be less abrasive than silica. This was because of their shape and how they were entrained into the filament contacts and loaded against a counterface. With both particles subsurface damage during stain removal was found to be minimal.

A simple model was built to predict stain removal rates with silica particles, which gave results that correlated well with the experimental data.

Keywords: teeth cleaning, stain removal, abrasive particles, toothbrush, toothpaste

1 INTRODUCTION

The removal of stain from teeth allows our smiles to be cosmetically acceptable to society of today. If stain is seen to cover more than five percent of an incisor tooth it is considered to be *cosmetically unacceptable* [1].

There are two main types of tooth stain, intrinsic and extrinsic. Intrinsic stains are caused by the natural colour of dentine showing through the translucent enamel layer on a tooth. The colour of dentine varies from person to person and may vary from white through to brown. These intrinsic stains are not possible to remove.

Extrinsic stain forms on the tooth surface. The most common of these stains is pellicle, which is initially a bacterium free layer 1-10 μm thick formed from proteins in the oral environment. Once it becomes infected with bacteria it becomes stained by tannin rich foods such as red wine or cationic agents such as chlorhexadine, commonly found in mouth rinses [2]. Work by White [3] and Sheen [4] has shown that chlorhexadine may promote the absorption of tannin rich foods such as tea or coffee into the pellicle layer. The mechanical properties of pellicle, such as hardness, have been found to be similar to those of dentine [5], but those of other stains can vary considerably depending on the length of accumulation time and other factors.

Stain can be observed as different colours, each colour with its most likely cause are summarised in Table 1. Although, as indicated, foodstuffs and tobacco have been shown to stain teeth, there has been no correlation found between the volume of food or amount of tobacco and the stain intensity [6].

Teeth are usually cleaned using a filament based toothbrush and a toothpaste, which consists of abrasive particles in a carrier fluid. The particles are made from materials such as calcium carbonate, sodium bicarbonate, precipitated silica, pumice and perlite. During brushing the particles are intended to be trapped and loaded at the filament tips and scrape away the softer

underlying stain (see Figure 1). The particle/filament interaction is therefore key to the cleaning performance.

Although optimum stain removal is desired from a toothpaste abrasive it is important that during the cleaning process that the underlying material (enamel or dentine) or soft gum tissue is not damaged. Abrasive selection is therefore quite difficult due to the varying properties of stain. Dentine is four to five times softer than enamel and therefore wear concerns would clinically be expected to more important with respect to dentine. Patients and practitioners, however, value cleaning formulations which are gentle to both materials [7, 8].

There are other components in toothpaste that act chemically to reduce stain and whiten teeth. Stain can be either dissolved or bleached using peroxides. Enzyme systems and absorbents are also used to soften the pellicle easing the removal process. This is important in regions of the mouth less accessible by a toothbrush.

The cleaning performance of toothbrushes and toothpastes is assessed using a number of different *in vivo*, *in vitro* and *in situ* tests. For the toothpastes, these are used to determine the stain removal capability and the abrasivity.

Typical *in vivo* tests involve using volunteers and controlling their diet and toothbrushing regimes while taking measurements of stain accumulation and removal. One example is a study carried out using a sample of forty volunteers [9] who were instructed to use low abrasive toothpaste for six weeks allowing stain to accumulate. Three independent observers carried out initial stain assessments on each individual. A hygienist then brushed their teeth under specified conditions before they were reassessed by the observers to assess the levels of stain removal. In this type of testing although the actual oral environment is used, there is little control over brushing technique and quantitative measurements are very difficult to obtain.

A number of simulators have been developed for carrying out *in vitro* testing (see for example [10, 11, 12, 13]). Most of these work by mechanically loading and moving a toothbrush head over a test specimen, which is typically made from bovine dentine, enamel or acrylic. With *in vitro* testing the level of control over brushing parameters is high, but specimens are not exposed to the actual oral environment and model stains have to be applied to specimens.

In situ tests offer a compromise and involve using dentine or enamel specimens mounted in devices worn in the mouth by subjects and then removed for *ex vivo* testing in a brushing simulator [14, 15]. Specimens can therefore be exposed to the chemical environment within the mouth, brushing can be controlled well and measurements are easier to take.

In all types of test the performance of the toothpaste or toothbrush is compared to that of a standard paste and brush.

In such testing, however, no investigations have been carried out to study the actual mechanism of material removal from a stain layer. Work has been undertaken to study particle/filament interaction visually [16], identified above as being critical in the cleaning process, which has shown how silica particles are entrained in a filament/counterface contact and subsequently loaded against the counterface. The effect of varying load and filament deflection was also qualitatively determined. Subsequent work was carried out using scratch testing to study and model the removal of material from hard tissue materials and dental restoratives [17], but did not investigate stain layers.

The aims of this work were to study material removal from a stain layer using simulated toothbrushing with both silica particles and perlite particles. Perlite particles are currently being introduced to toothpastes with the aim of reducing their abrasivity without compromising cleaning power. They differ considerably in geometry from silica particles used in previous studies although perlite is actually largely made up of silica with aluminium

oxide and sodium oxide being the next largest constituents. They are flat in nature (see Figure 2) (reminiscent of broken egg shells) with widths (up to 100 μm) many times their thickness ($\sim 2 \mu\text{m}$). Silica particles are granular in shape.

Visualisation studies were initially carried out to see how the entrainment and loading of perlite particles in a filament/counterface contact differed from that previously seen for silica particles. Abrasion tests were then run to determine for a given load how many particles were causing material removal and the actual material removal mechanisms and rates from a stain layer.

2 VISUALISATION STUDIES

2.1 Test Apparatus

Simple optical apparatus was used to enable the visualisation of perlite particles in a simulated teeth cleaning contact (shown in Figure 3). This was the same apparatus as used in the previous work using $\sim 10 \mu\text{m}$ silica particles [16]. A toothbrush head was loaded against a rotating glass disc using a hydraulic actuator. The toothbrush head was located in a clip attached to the hydraulic actuator. The fluid/abrasive particle mixture was applied either to the brush head prior to loading or fed in during disc rotation. The contact region was observed using a positionable microscope attached to the rig. Image capture was by a CCD video camera.

2.2 Specimens and Operating Conditions

A standard toothbrush design consisting of equi-spaced tufts of filaments of equal length was used in the tests (as shown in Figure 4).

Load and brushing speed used in the tests were based on reported measurements taken during *in vivo* experiments [18, 19]. A load of 225g was used with a sliding speed of 30mm/s. Perlite particles were mixed with water at 1% concentration by mass.

2.3 Results

Observation of the filament tip contacts showed that the perlite particles were passing through the tip contacts in a flat orientation, as shown in Figures 5a and 5b. Particles continued to pass through the contact for the duration of the test and did not accumulate around the filament tips. The particles appeared to re-orientate themselves just before entering the filament tip contact as if to find the path of least resistance. This was very different to the action of silica particles under similar conditions [16]. They were seen to build-up around the filament tip, as shown in Figure 5c, with some passing through the tip contact at low loads and filament deflections. Even the largest perlite particles were able to pass through the contact. Similar sized silica particles were unable to do so and were deflected away from the filament tip.

Increasing load stopped perlite particles from entering the contact. This was probably due to the deflected shape of the filaments. At higher loads silica particles were also not able to enter the contact, but as with lower loads, accumulated around the edge of the contact [16].

3 ABRASION EXPERIMENTS

Two types of abrasion test were carried out to study scratch formation and relate this to particle behaviour seen during visualisation studies. The first set of tests was carried out to try to determine the mechanism of abrasion by inspection of scratched surfaces. The second set

of tests was carried out to study the material removal process from a model stain layer from the morphology of the scratches formed and the stain removal rate.

3.1 Apparatus

The abrasion tests were performed using a linear reciprocating rig. The set-up used is shown in Figure 6. A perspex specimen was clamped into a holder mounted on the rig. The fluid/particle mixture was applied to the specimen using a pipettor to ensure an equal amount was used for each test. The toothbrush head, clamped to the end of an arm attached to the oscillator, was then loaded against the perspex specimen.

3.2 Specimens and Operating Conditions

Standard toothbrushes consisting of 34 equi-spaced tufts of 36 nylon filaments (0.2mm diameter and 11.2mm long) were used in the tests (see Figure 4). A new brush head was used for each test. Particles were mixed with water at 1% concentration by mass.

Scratch tests were carried out using both silica and perlite particles to assess what differences there were in abrasive behaviour due to varying particle geometry. A test was also carried out with no particles. A load of 200g was used in all the tests. Peak to peak motion was 5mm.

Tests were run for either 4500 cycles or 50 cycles at a frequency of 5Hz. This allowed long term scratch behaviour to be observed, for example how many filaments were actually in contact with the perspex counterface and trapping particles and causing scratches etc. as well as short term behaviour to determine how many particles were causing scratches at a single point in time.

Stain removal tests were carried out by applying a model stain, created using an organic dye, painted onto the perspex specimens. Stain thickness was assessed using a profilometer. As shown in Figure 7, the thickness was approximately 1 μm . A range of loads were used from 10 to 300g and the brushing time was 15 seconds (75 cycles). These tests were run using silica (10 μm) and perlite particles (again at 1% concentration by mass) and with no particles. A test was also carried out at 200g to determine how stain removed varied with time. The test was stopped every 15 seconds (75 cycles) to assess stain removal. Tests were repeated at each set of conditions two or three times to check for repeatability.

To establish the amount of stain removed a grid of 2×2 mm squares was placed over the brushed area of stain and the number of squares containing scratches through to the perspex was counted. Results were plotted as the proportion of the brushed area with scratches through to the perspex counterface (number of squares with scratches through to perspex/number of squares in brushed area). This is quite a crude method and will clearly give an upper estimate for the stain removed.

3.3 Results

Figure 8 shows typical scratch patterns attained from tests with perlite and silica particles. It can be seen that less scratches occurred when using perlite and that they were different in nature. Scratches caused by perlite were less uniform than those caused by silica particles. The trapped perlite particles appear to be less stable than silica particles; presumably they are not held so rigidly by the filament. Scratches caused by perlite particles can also be seen to be less deep.

The peak to peak distance moved by the reciprocating arm was 5mm, but the scratches were only about 1mm long (for tests with silica). This is because there is a lag in the filament motion as some of the sliding distance of 5mm is taken up by elastic deformation of the filaments. This was also observed in previous scratch testing [17]. It is also clear that the perlite scratches are shorter than the silica scratches. Actual scratch lengths were measured and a mean value is given in Table 2. Scratch numbers were also determined. For the long 4500 cycle tests the number of groups of scratches (see Figures 8c and 8d) indicated how many filaments were trapping particles (shown in Table 2 as the proportion of total filaments, i.e. number of scratch groups/total number of filaments) and for the short 50 cycle tests to give an estimate of how many particles were cutting and causing scratches at any one moment (shown in Table 2 as the proportion of filaments trapping particles, i.e. number of scratches/number of filaments trapping particles).

Scratch numbers, particularly for the short tests were difficult to assess, however, it could be seen that there were a similar number of filaments in contact for all tests, but less perlite particles were cutting at any one moment than silica particles.

Figure 9a shows scratches formed during the control test with no particles. Clearly the filament tips were sharp enough to cause light scratches through to the perspex. From the bunching of scratches observed, however, it was evident that only a few of the filaments were causing material removal.

Figure 9b shows scratches formed during a test using perlite particles. Again more scratches were formed than in the control test. Stain debris was visible in the stained region, removed from the surface by the action of the perlite particles (see Figure 9b). Most scratches did not cut through the entire thickness of the stain layer. It appears that just a surface layer is

removed. Where scratches did cut through it was quite patchy. The scratches were much wider than those formed in the control test with no particles.

Scratch formation when using silica particles was more severe than that with perlite particles (see Figure 9c). Unlike the perlite samples, at low magnification it was possible to see scratches that had cut right through the stain. As shown in Figure 9c more scratches had cut right through the stain and they were clean scratches. They were also straighter and more uniform along the length. It was not possible with either perlite or silica particles to assess whether the scratches had caused damage to the perspex counterface.

Figure 10 shows stain removal rates against load (determined using a grid of squares as described previously in “Specimens and Operating Conditions” section). Clearly silica is more abrasive than perlite and removes stain more effectively. Filaments on their own with no particles, as already seen in Figure, are able to remove stain. The relationship between stain removal and load is interesting for all cases. The silica drops before rising again and for perlite and no particles the stain removal rate drops with load. Stain removal, as observed earlier, is tied in closely with the particle trapping and loading against the counterface material. This will change as the load increases and the filaments deflect. The relationship between filament shape and subsequent particle loading and how this impacts on stain removal will be discussed later.

Figure 11 shows how stain removal at a load of 200g varies with time. Again silica stain removal is shown to be higher.

After the stain removal tests were complete the perspex specimens were cleaned to examine the counterface surfaces for damage. Some examples are shown in Figure 12, along with typical scratches in the stain for each case. As can be seen there are very few scratches in the Perspex compared to the stain for both silica and perlite. The transverse scratches shown in

the photographs are pre-existing machining marks in the perspex sheets. At 200g the filaments on their own produced a few scratches in the counterface, which was unexpected. It should be noted that these are snapshots of the whole counterface, however, the general trend is that there is little subsurface damage when stain is being removed.

4 MODELLING STAIN REMOVAL

The simple model developed by Lewis & Dwyer-Joyce [17] for material removal during abrasive teeth cleaning using silica particles was adapted for this work to predict stain removal.

The original modelling was achieved using a theoretical determination of particle indentation to calculate scratch depths, ploughed area and the proportion of material removed. Scratch test data was then used to determine the length of the scratch and the number of scratches likely to occur. Finally, the model was validated using experimental test data from the literature.

The model was developed assuming that a particle trapped at a filament tip acts like a micro-indenter (see Figure 13). Silica particles were assumed to be cubes indenting on one corner.

Hardness, H (N/m^2), is defined as the load (W (N)) divided by the surface (pyramidal) area (A (m^2)) of the indentation. This can therefore be used to derive the depth and width of the indentation caused by a particle trapped at a filament tip. In scratching only the front part of the indenter (particle) is supporting the load so only this area should be considered (see Figure 14).

Factors were included to take account of the proportion of filaments with trapped particles that were cutting, filament drag, elastic recovery in the scratch and the displaced material

actually lost as wear debris, which gave the final equation for the volume of material lost per brush stroke, V_b as:

$$V_b = NbtA_s gfls \quad (1)$$

where N is the total number of filaments, b is the proportion of filaments in contact with the material, t is the proportion of these with a trapped particle, A_s is the cross-sectional area of indentation, g is the change in the indentation cross-sectional area, A_s , due to elastic deflection and recovery, f is the proportion of displaced material lost as wear debris, l is the brushstroke length and s is the scratch/brush lag factor (scratch length/brush stroke length).

Values for factors g and f were determined from experimental data generated by Jardret et al. [20] during scratch experiments on a range of materials to study surface elastic deflection, groove elastic recovery and plastic deformation. The data was used to plot g (reduction in scratch cross-sectional area factor) and f (material loss factor) against E/H .

In this work only the area of the scratch (viewed from above), A_p , was considered, rather than the volume of material. This was calculated using the scratch width, w , which was derived from the depth and the particle geometry. So the total area of stain removed in one brush stroke, assuming that the scratch depth is sufficient to penetrate through the whole stain layer, is given by:

$$A_p = Nbtwls \quad (2)$$

The values for factors s , b and t were taken from the results of the scratch testing shown in Table 1. These are therefore only valid for the load at which this testing took place, 200g, as their relationship to load has not yet been ascertained.

To validate the model the results were compared with the stain removal data from the tests carried out to assess stain removal against time for silica particles (see Figure 15).

The stain removed per brushstroke will not be the same as time progresses because the amount of stain left will reduce, so if an even distribution of cutting particles is assumed, it is less likely that stain will be removed with each subsequent brush stroke. The model therefore has to be iterative to accommodate this. It was run for 15 second intervals. After the first interval the proportion of stain removed was calculated. For the second interval this value was multiplied by 1 minus the proportion removed in the first interval and so on.

The brushing parameters used in the model and data relating to the scratches and the stain removed are given in Table 3. The model predictions are compared with the test results in Figure 15. Values of E and H for pellicle were used as an approximation for those of the organic dye in the absence of actual data (giving $E/H = 29$).

This model has been developed for the blocky shaped silica particles. Perlite particles are flat and plate-like shapes. There are a number of ways that perlite particles could be modelled, for example as flat squares (cutting on one edge or a corner) or discs or as a shallow “V” shape. However, the scratch widths and or depths turn out to be very dependent on the assumed shape and orientation of the particle and the angle of cutting. More work is needed on visualising perlite particle in a contact to establish exactly how they cut through stain before an accurate prediction can be produced. Also the stain removal due to filaments with no particle trapped needs to be incorporated as a small proportion cause stain removal.

5 DISCUSSION

5.1 Particle Entrainment and Scratch Morphology

It is clear from the visualisation studies carried out that perlite particles enter the filament tip contact region in a flat orientation. This is critical in determining their likely abrasive action. A flat rather than an edge orientation should give a less severe action.

In the flat orientation the large front edge on the perlite particles may have been expected to cause a large amount of material removal. Scratch widths seen in stain removal tests, however, are similar in width to those with silica (see Figures 9b and 9c). It is not clear which profile is cutting with perlite particles. However, the particles are not completely flat and it could be envisaged that under load only a small part of the front edge is cutting, as shown in Figure 16, which could explain the similarities in scratch width.

It was evident from observation of the stain removal scratches that silica scratches were deeper. Far more scratches could be seen where the stain layer had been completely removed exposing the substrate. Perlite scratches in the stain were jagged and cutting was intermittent. Clearly the particles are not stable when under load at the tip of a filament. This was also highlighted in the abrasion tests where silica scratches were uniform in nature while the perlite scratches were in more random directions and not continuously (see Figure 7). Cutting with a *flat edge* rather than a *point* would probably be less stable and hence much straighter scratches were seen with silica.

It was also clear that more scratches were created when using silica particles in both the abrasion and stain removal tests.

It was evident from scratch length measurements taken (see Table 2) that filament lag was occurring, as seen in previous work [17]. Perlite scratch lengths, however, were clearly

shorter than those with silica. This may have been due to the less stable nature of the entrainment trapping process leading to shorter trapping times. Scratch numbers were similar to those seen during previous work. It was noticeable, however, that there were less scratches being formed at any one moment with perlite than with silica. This was probably because there are many more small silica particles in a given mass than larger perlite particles. The less stable trapping of perlite particles will also have had an effect as well as the fact that more silica particles accumulate around filament tips and are therefore more likely to be entrained and trapped at a filament tip.

5.2 Stain removal

The stain removal rates seen in Figure 10, were very interesting. Firstly the removal rates with no particles clearly indicate that brushing alone with no toothpaste will remove a certain amount of a stain layer. This is because the filament tips can end up being quite pointed as shown in Figure 17. The removal rates reduced with increasing load as the filaments deflect further and the side of the tip will be in contact with the stain rather than the tip, decreasing the cutting potential.

Similar results were seen for the perlite particles, although the stain removal rates were slightly higher. The stain removal decreases with increasing load in this case because as the filament deflects it becomes harder for the perlite particle to enter the filament tip contact, as seen in the visualisation studies.

The stain removal rates with silica particles were much higher indicating that silica is more abrasive. The variation in removal rate with load was different to perlite. It was high initially before dropping and then rising to its original level again. This again can be explained by looking at the particle entrainment behaviour with increasing load. At low loads and filament

deflection the particles are more likely to be trapped and loaded at the tip contact and therefore stain removal is possible (see Figure 18). As the filaments start to deflect under increasing loads less and less particles enter the contact stain removal reduces. Most particles accumulate around the tip where they are not under load. As the load continues to increase, however, the particles accumulating around the filament tip will be loaded against the stain layer with greater and greater force and therefore be able to remove more stain again.

In all cases the counterface damage was low during stain removal. This is despite the fact that when no stain is applied the particles are able to scratch the perspex counterface. This clearly indicates the necessity to avoid over brushing of teeth. With some improvements the stain removal model proposed could be used to try and optimise recommended brushing times to help toothbrush users avoid damaging teeth and gums.

6 CONCLUSIONS

Tests have been performed to compare and contrast the abrasive and stain removal actions of two types of toothpaste particle. Silica particles are small and blocky whilst perlite is large and flat.

Visualisation studies showed that the perlite particles pass under filament tips in a flat orientation. The particles appeared to re-orientate themselves just before entering the filament tip contact as if to find the path of least resistance. Perlite particles did not accumulate at a filament tip as silica particles have been seen to.

Perlite scratches were less uniform than silica scratches indicating a less stable trapping process occurred, probably caused by perlite scratching with an edge rather than a point as with silica. Fewer scratches were caused by perlite particles than silica particles, the scratches

were also shorter. This was due to the fact far less perlite particles were present and the less stable trapping process seen. Perlite particles produced shallower scratches than silica. This was because the perlite particles cut with a flat edge.

Stain removal was also more uniform with silica. Perlite scratches in stain were jagged and intermittent. This indicates that particles are not stable when under load at the tip of a filament. Stain removal rates were higher with silica and showed different behaviour to perlite as load and filament deflections were increased. The changes in stain removal rates with increasing load could be directly attributed to the change in particle entrainment and loading seen during the visualisation studies.

Little counterface damage occurred during the stain removal process with either silica or perlite.

A stain removal model has been developed that has shown good correlation with experimental data for silica particles. The enable reliable predictions for perlite particles more information is needed about the way they are orientated and remove material.

REFERENCES

1. G.K. Stookey, T.A. Burkhard, B.R. Schemehorn, *In vitro* removal of stain with dentifrices, *Journal of Dental Research* 61 (1982), 1236-1239.
2. L.M. MacPherson, K.W. Stephen, A. Joiner, Comparison of a conventional and modified tooth stain index, *Clinical Periodontology*, 27 (2000), 854-859.
3. D.J. White, Development of an improved whitening dentifrice based upon 'stain-specific soft silica' technology, *Journal of Clinical Dentistry* 12 (2001), 25-29.
4. S. Sheen, M. Addy, An *in vitro* evaluation of the availability of cetylpyridinium chloride and chlorhexadine in commercially available mouth rinse products, *British Dental Journal* 194 (2003), 207-210.

5. P.L. Dawson, J.E. Walsh, T. Morrison, Dental stain prevention by abrasive toothpastes: a new *in vitro* test and its correlation with clinical observations, *Journal of Cosmetic Science* 49 (1998), 275-283.
6. G.C. Forward, Role of toothpastes in the cleaning of teeth, *International Dental Journal* 41 (1991), 164-170.
7. F. Barbakow, F. Lutz, T. Imfeld, Relative dentin abrasion by dentifrices and prophylaxis pastes: implications for clinicians, manufacturers and patients, *Quintessence International* 18 (1987), 29-34.
8. J.J. Hefferren, Historical view of dentifrice functionality methods, *Journal of Clinical Dentistry* (1998) 9, 53-56.
9. P.M. Baxter, W.B. Davis, J. Jackson, Toothpaste abrasive requirements to control naturally stained pellicle, *Journal of Oral Rehabilitation* 8 (1981), 19-26.
10. R.S. Manly, Factors influencing tests on abrasion of dentin by brushing with dentifrice, *Journal of Dental Research* 23 (1944), 59-72.
11. J.R. Heath, H.J. Wilson, Abrasion of restorative materials by toothpaste, *Journal of Oral Rehabilitation* 3 (1976), 121-138.
12. E. Harrington, P.A. Jones, S.E. Fisher, H.J. Wilson, Toothbrush - dentifrice abrasion - a suggested standard method, *British Dental Journal* 153 (1982), 135-138.
13. J.R. Condon, J.F. Ferracane, A new multi-mode oral wear simulator, *Dental Materials* 12 (1996), 218-226.
14. M. Addy, J. Hughes, M.J. Pickles, A. Joiner, E. Huntington, Development of a method in situ to study toothpaste abrasion of dentine, *Journal of Clinical Periodontology* 29 (2002), 896-900.
15. A. Joiner, M.J. Pickles, J.R. Matheson, E. Weader, L. Noblet, E. Huntington, Whitening toothpastes: effects on tooth stain and enamel, *International Dental Journal* 52 (2002), 424-434.
16. R. Lewis, R.S. Dwyer-Joyce, M.J. Pickles, Interaction between toothbrushes and toothpaste abrasive particles in simulated tooth cleaning, *Wear* 257 (2004), No. 3-4, 368-376.

17. R. Lewis, R.S. Dwyer-Joyce, Interaction of toothbrush filaments and toothpaste particles during simulated abrasive cleaning, in press *Journal of Engineering Tribology*, Proceedings of the IMechE Part J (2005).
18. E.A. Phaneuf, J.H. Harrington, P.P Dale, G. Shklar, Automatic toothbrush: a new reciprocating action, *Journal of the American Dental Association* 65 (1962) 12-25.
19. C.R. Allen, N.K. Hunsley, I.D.M. MacGregor, Development of a force-sensing toothbrush using PIC micro-controller technology for dental hygiene, *Mechatronics* 6 (2) (1996) 125-40.
20. V. Jardret, H. Zahouani, J.L. Loubet, T.G. Mathia, Understanding and quantification of elastic and plastic deformation during a scratch test, *Wear* 218 (1998), 8-14.

Figure Captions

- Figure 1 Abrasive Stain Removal
- Figure 2 Perlite Particles
- Figure 3 Visualisation Apparatus
- Figure 4 Standard Toothbrush used during Testing
- Figure 5 Particle Interaction with a Filament Tip Contact: (a-b) Perlite; (c) Silica [Silica observations from 16]
- Figure 6 Reciprocating Toothbrushing Abrasion Test Apparatus
- Figure 7 Profile of a Model Stain Layer created using Organic Dye
- Figure 8 Scratch Patterns for 4500 Cycle Tests Run with: (a & c) Silica Particles; (b & d) Perlite Particles
- Figure 9 Scratches Formed in a Model Stain during (a) a Control Test with no Particles; (b) Tests using Perlite Particles; (c) Tests using Silica Particles
- Figure 10 Proportion of Brushed Area with Scratches through to Perspex against Brushing Load
- Figure 11 Proportion of Brushed Area with Scratches through to Perspex against Brushing Time
- Figure 12 Stain and Respective Counterface Scratches for Tests Run for 15 Seconds at 200g with (a) No Particles; (b) Silica Particles and (c) Perlite Particles
- Figure 13 Particle Trapped at a Filament Tip
- Figure 14 Particle and Scratch Geometry
- Figure 15 Silica Stain Removal Model Predictions Compared with Experimental Data
- Figure 16 Material Removal Caused by Perlite and Silica Particles Trapped at a Filament Tip
- Figure 17 Filament Tips
- Figure 18 Changing Filament Deflection and Silica Particle Trapping with Increasing Brush Load

Table Captions

- Table 1 Stain Colours and their Causes
- Table 2 Scratch Lengths and Numbers (Silica data from [16])
- Table 3 Brushing Parameter Inputs for Model Predictions

Figure 1

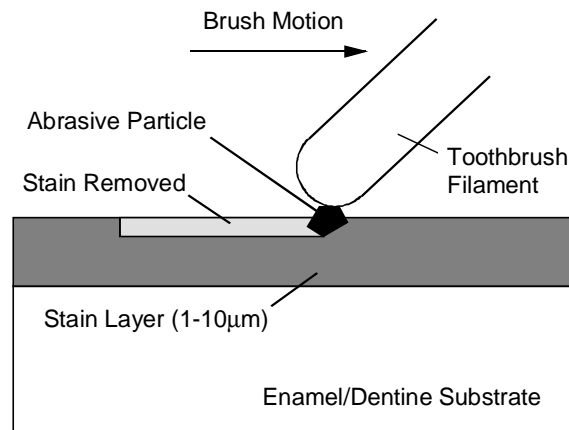

Figure 2

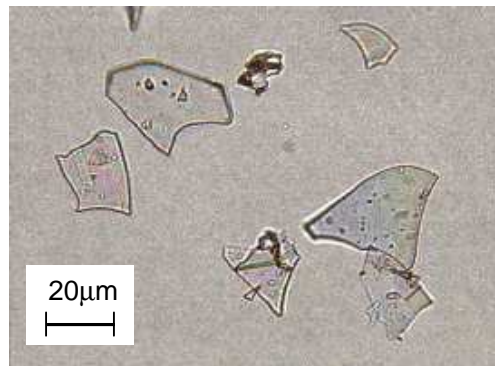

Figure 3

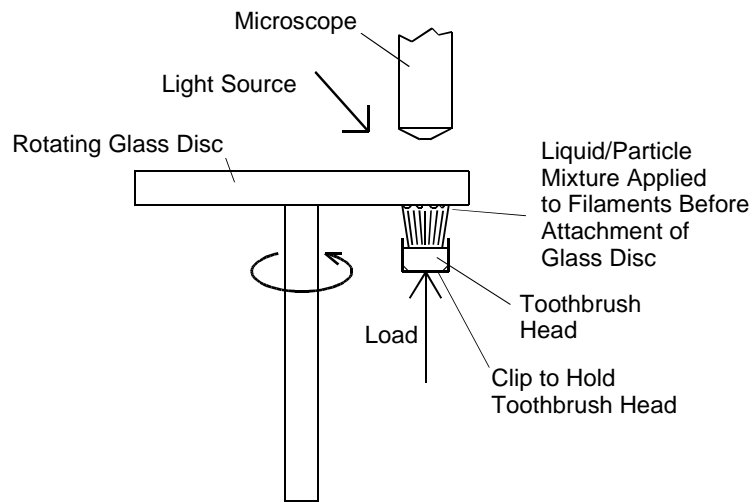

Figure 4

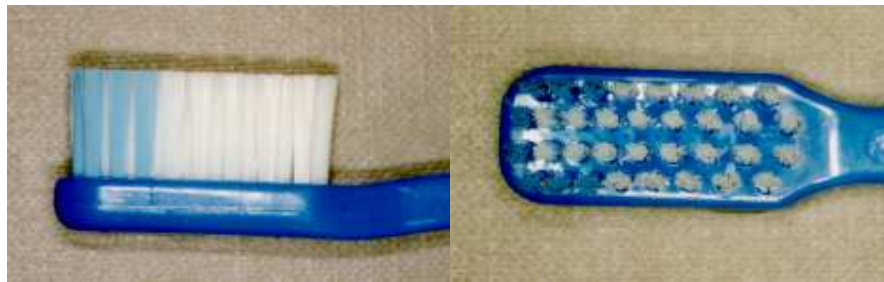

Figure 5

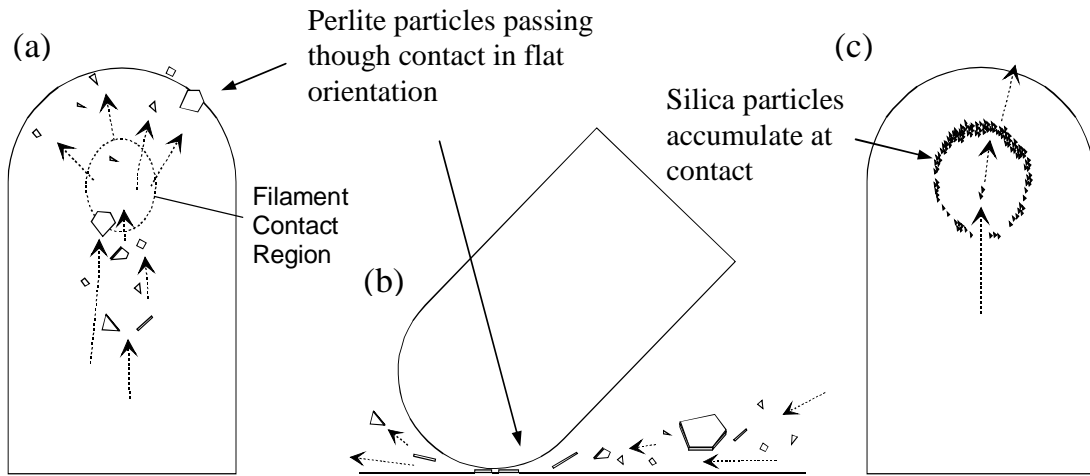

Figure 6

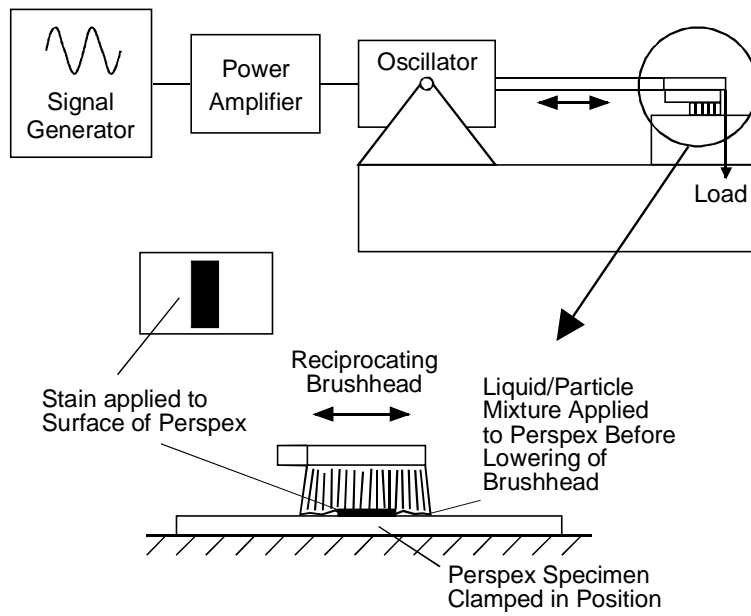

Figure 7

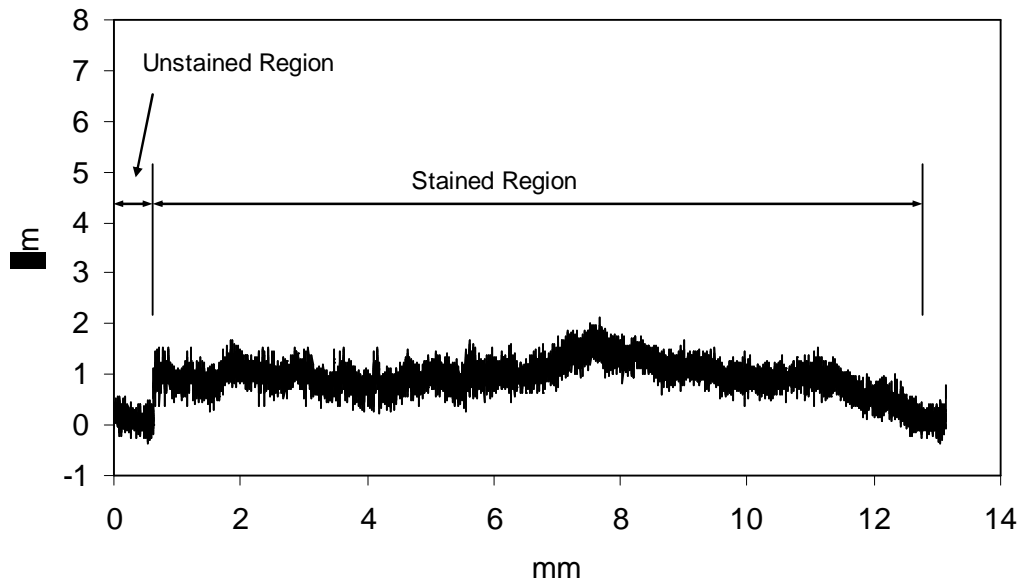

Figure 8

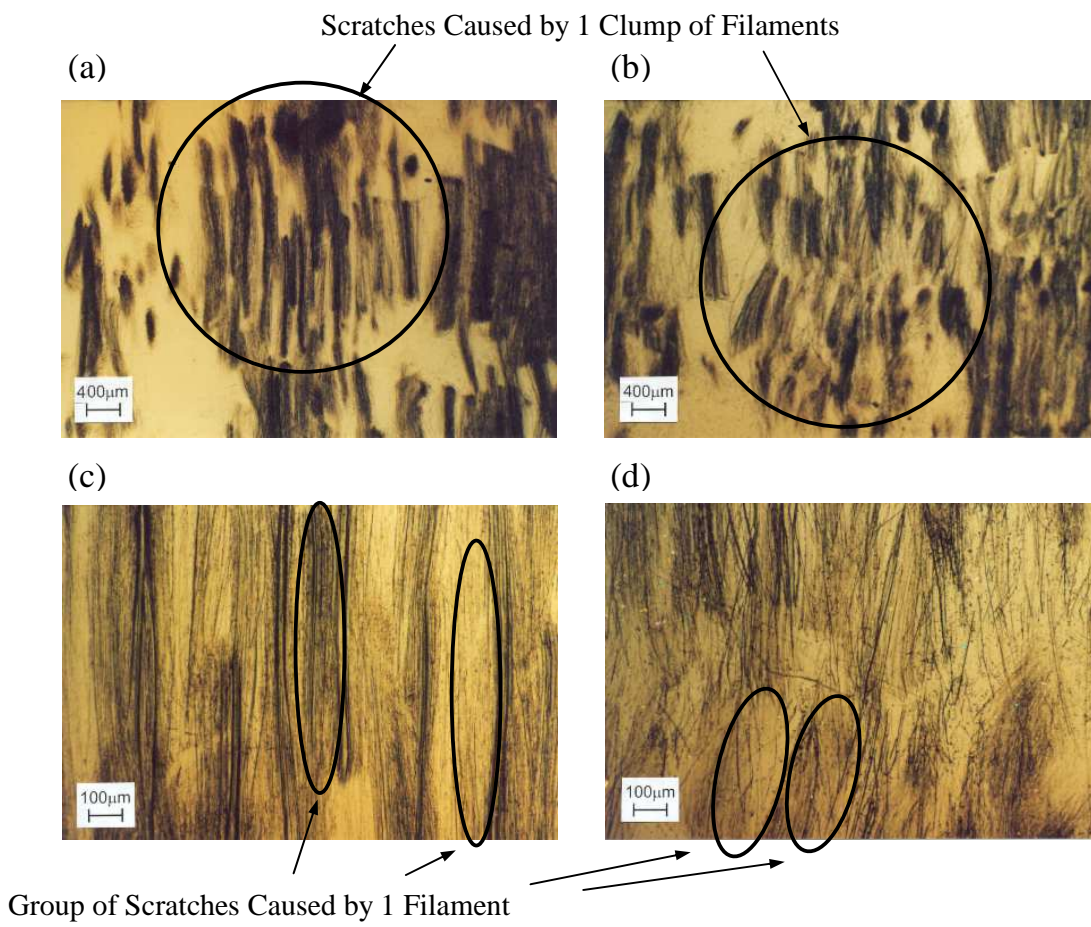
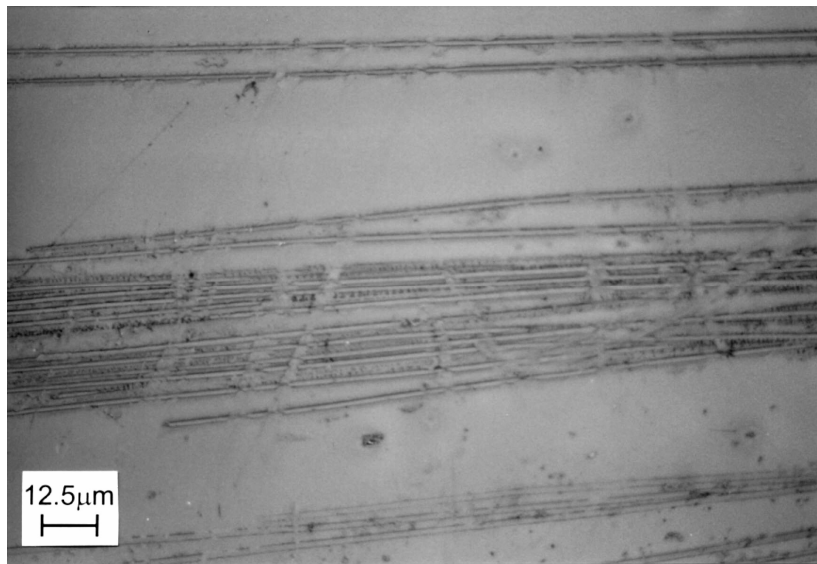

Figure 9

(a)

Brushing
motion
↔



(b)

Jagged scratch
- intermittent
cutting

Brushing
motion
↔

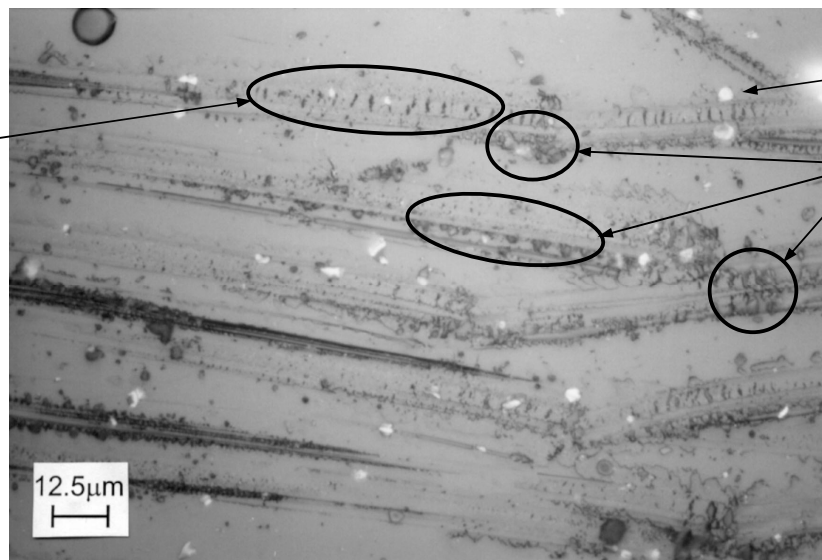

Perlite particle

Stain debris

(c)

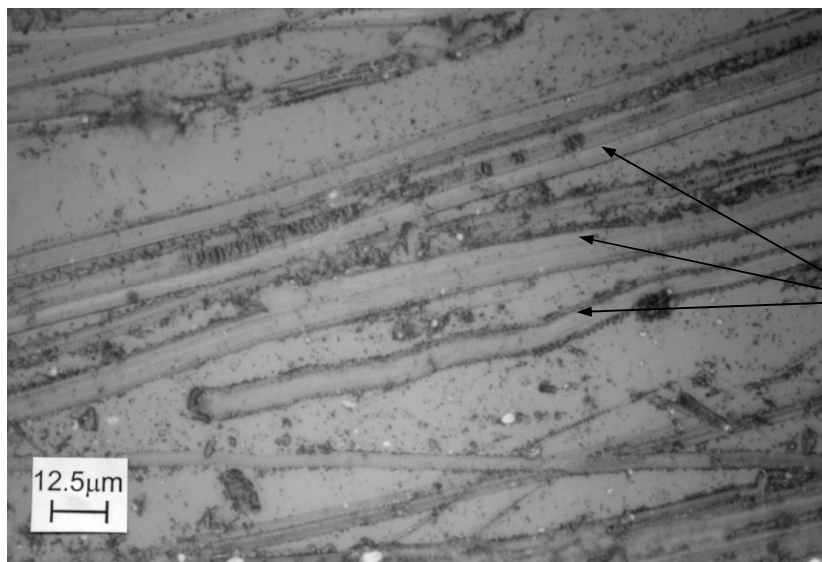

Many scratches
have cut
through the
stain to expose
perspex
counterface

Figure 10

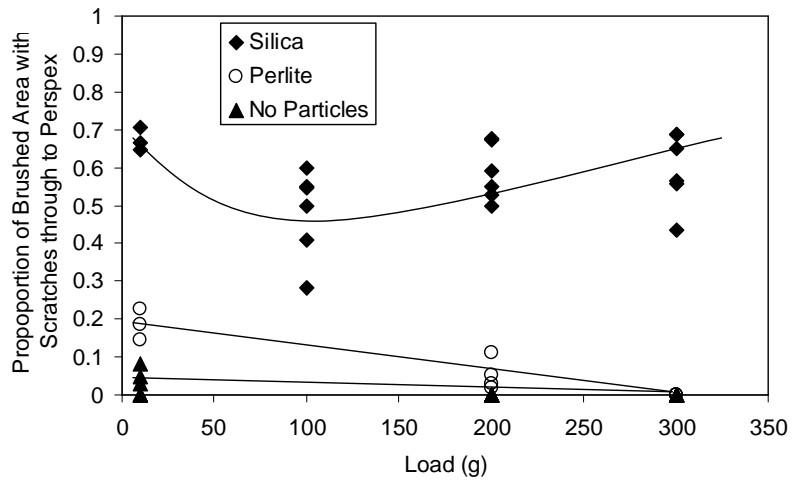

Figure 11

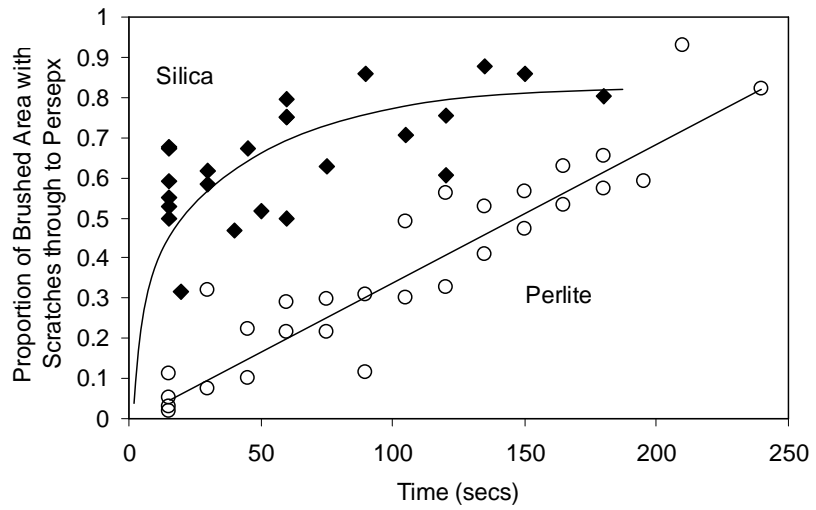

Figure 12

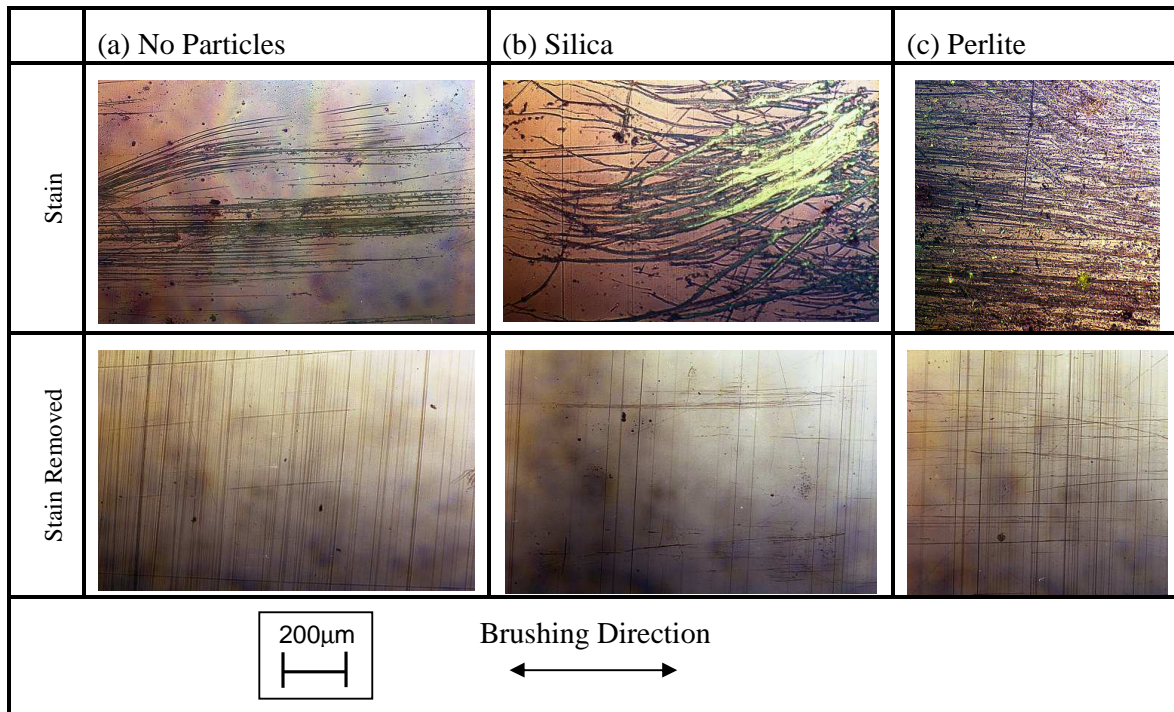

Figure 13

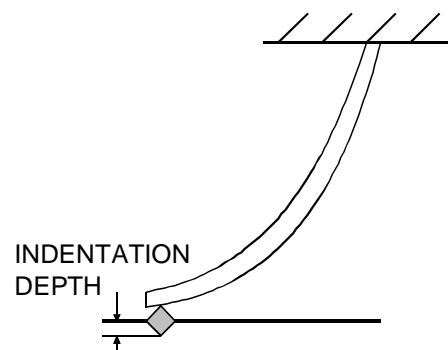

Figure 14

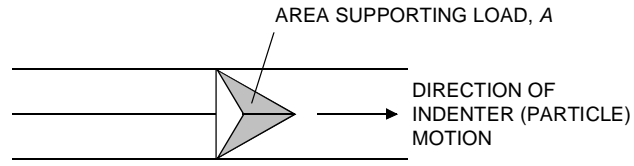

Figure 15

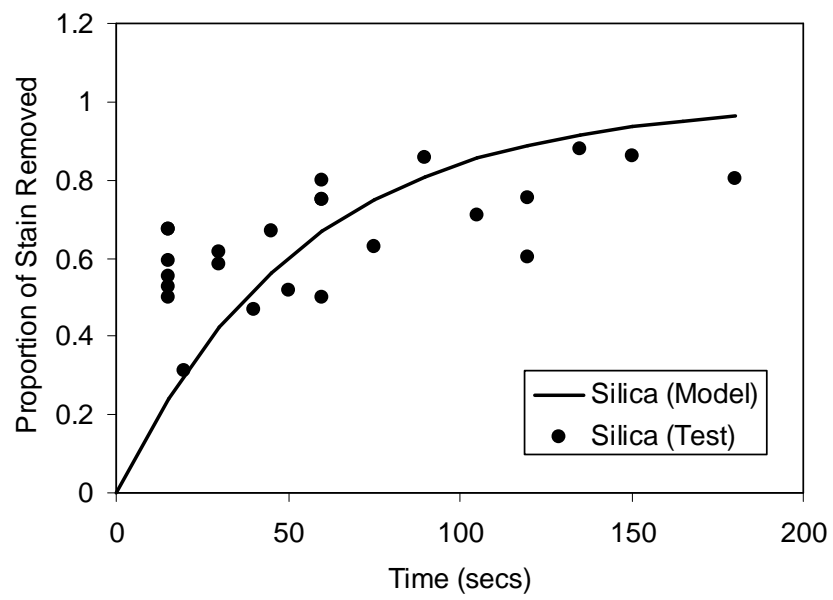

Figure 16

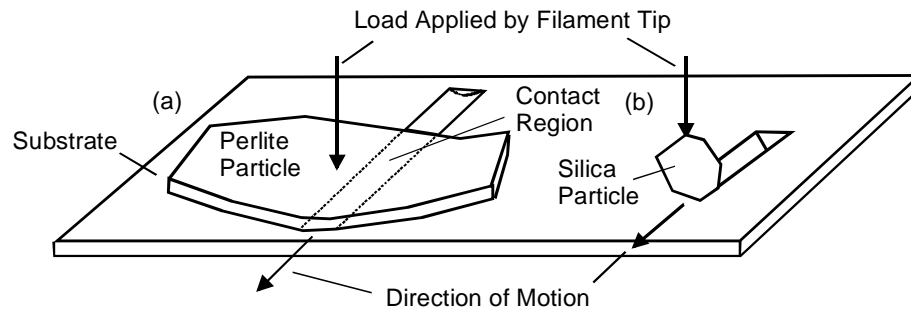

Figure 17

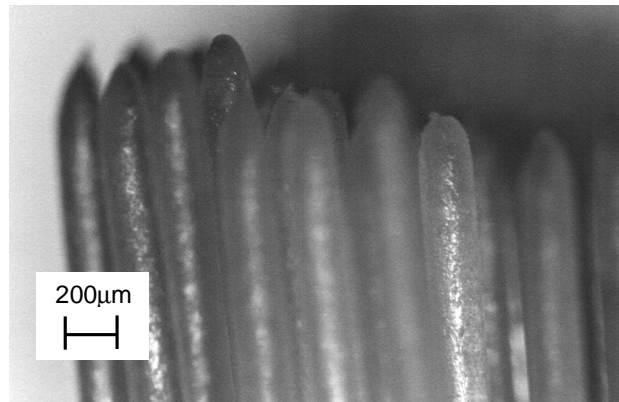

Figure 18

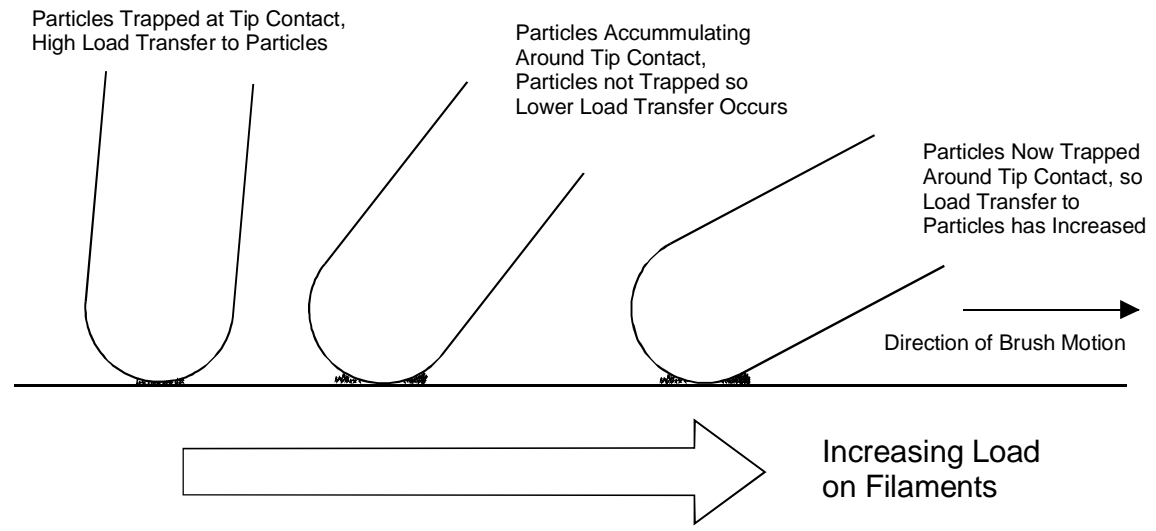

Table 1

Colour	Source
Green, Orange, Black	Chromogenic bacteria
Yellow, Brown	Tobacco, Food

Table 2

	Perlite	Silica
Length of scratch (mm)	0.8	1.1
Proportion of filaments in contact and trapping particles	70%	72%
Proportion of filaments with particles cutting at any one moment	10%	15%

Table 3

Particle	Silica
Load on Brush Head (g)	200
Scratch Depth (μm)	0.98
Scratch Width (μm)	2.4
Brush Stroke Length (mm)	5
Number of filaments, N	1360
Proportion of Filaments in Contact with Counterface, b	0.97
Proportion of filaments in contact with a trapped particle, t	0.15
Filament Drag Factor, s	0.22
f	0.5
g	0.7
Number of Strokes	150
Proportion of Stain Removed in first 15 second interval	0.24