



This is a repository copy of *Performance assessment of triple redundant nine-phase delta- and wye-connected permanent magnet-assisted synchronous reluctance motor under healthy and fault conditions.*

White Rose Research Online URL for this paper:
<http://eprints.whiterose.ac.uk/147875/>

Version: Published Version

Proceedings Paper:

Shi, Y., Wang, J. orcid.org/0000-0003-4870-3744 and Wang, B. (2019) Performance assessment of triple redundant nine-phase delta- and wye-connected permanent magnet-assisted synchronous reluctance motor under healthy and fault conditions. In: The Journal of Engineering. The 9th International Conference on Power Electronics, Machines and Drives (PEMD 2018), 17-19 Apr 2018, Liverpool, United Kingdom. Institution of Engineering and Technology (IET) , pp. 3563-3567.

<https://doi.org/10.1049/joe.2018.8170>

Reuse

This article is distributed under the terms of the Creative Commons Attribution-NonCommercial (CC BY-NC) licence. This licence allows you to remix, tweak, and build upon this work non-commercially, and any new works must also acknowledge the authors and be non-commercial. You don't have to license any derivative works on the same terms. More information and the full terms of the licence here:
<https://creativecommons.org/licenses/>

Takedown

If you consider content in White Rose Research Online to be in breach of UK law, please notify us by emailing eprints@whiterose.ac.uk including the URL of the record and the reason for the withdrawal request.



eprints@whiterose.ac.uk
<https://eprints.whiterose.ac.uk/>

Performance assessment of triple redundant nine-phase delta- and wye-connected permanent magnet-assisted synchronous reluctance motor under healthy and fault conditions

eISSN 2051-3305
Received on 25th June 2018
Accepted on 30th July 2018
E-First on 30th April 2019
doi: 10.1049/joe.2018.8170
www.ietdl.org

Yanwen Shi¹ ✉, Jiabin Wang¹, Bo Wang¹

¹Department of Electronic and Electrical Engineering, University of Sheffield, UK

✉ E-mail: yshi27@sheffield.ac.uk

Abstract: In this study, the performance of a triple redundant nine-phase permanent magnet-assisted synchronous reluctance motor with delta-connected windings is comprehensively assessed and compared with that of wye-connected winding under healthy and fault conditions, including open circuit, inter-turn short-circuit and terminal short circuit. The steady-state torque behaviour, loss, efficiency and temperature distribution of the two winding configurations are analysed and compared. It is shown that the delta-connected winding has higher output torque under one phase open-circuit fault and lower inter-turn short-circuit current with three-phase terminal short circuit.

1 Introduction

All electric aircraft (AEA) and more electric aircraft (MEA) have attracted increasing attention due to growing demand for low carbon air transport. It is desirable that electric drives in such safety critical applications are fault tolerant with high torque/power density, high efficiency and low maintenance cost [1]. While permanent magnet (PM) machine is an attractive candidate for meeting these requirements, the presence of PM field under fault conditions is of major concern.

Many papers have investigated typical fault conditions of PM machines and their responses under these fault conditions. Uncontrolled generator mode and open-circuit (OC) faults are relatively less harmful among all the faults because of the small- or zero-phase currents [2]. Inter-turn short-circuit (SC) fault is particularly critical since it leads to a large circulating current many times greater than the rate in the faulted turns. This may give rise to a local hotspot and ultimately cause a complete insulation failure of the winding as well as irreversible demagnetisation of magnets. It is also known [3] that the inter-turn short-circuit currents are dependent on many factors, such as the number or the position of the SC turns. One turn short-circuit located near the slot opening will lead to the highest fault current. Symmetrical three-phase terminal short circuit may be applied via the inverter as a mitigation measure to reduce the inter-turn short-circuit current. Thus, the ability to tolerate a single turn short circuit in the worse location is most demanding for realisation of a fault-tolerant PM drive.

A number of fault tolerant machine drives have been reported in the literature. The most classical and straightforward method is to employ redundant machine-drive systems. A drive with two electric motors mechanically connected either in series or in parallel fed by two separate inverters and power supplies are described in [4, 5]. However, they usually have low power density and torque density due to large space and extra accessories. Modular PM machines have been investigated extensively in [6–8] because of inherently fault tolerant capability. The modular PM machine usually has concentrated coils which are wound either on adjacent teeth or on alternate teeth leading to magnetic and thermal isolations. Each single phase is controlled by an H-bridge PWM converter resulting in electrical isolation. It also has high inductance which could limit the short-circuit current. However, the disadvantages of the modular PM machines are also obvious.

The fractional slot concentrated winding yields high magnetomotive force (MMF) space harmonics, causing high eddy current loss in the rotor magnets [9]. Additionally, the modular machine with concentrated windings has very small reluctance torque. Therefore, increase in torque capability often leads to large back electromotive force (EMF) and excessive inter-turn short current even after application of terminal short circuit [6].

Multiple phase (>3) machines reported in [10] can continuously operate at the loss of more than one phases with an appropriate control algorithm. They have much better fault tolerance than three-phase machines [11], but the multiple phase drive requires a specific inverter control which may increase the cost. To improve that, multiple three-phase PM machines fed by standard three-phase drives have been investigated in [12, 13].

A triple redundant, 9-phase (3 × three-phase), 36-slot, 6-pole permanent magnet-assisted synchronous reluctance motor (PMASynRM) with wye-connected winding configuration as shown in Fig. 1 is reported in [13]. ABC, DEF and GHI each forms a balanced and non-overlapping three-phase winding to have physical and thermal isolations between different three-phase sets. Further, each three-phase set is controlled by an independent inverter to have the electrical isolation. The performance of the drive under healthy condition and various fault conditions, including open circuit, one three-phase short circuit, and inter-turn short circuit etc., has been assessed in [13]. The results show that this machine has high saliency which leads to low permanent magnet usage, inherent large reluctance torque, high efficiency and torque density. All the above features are conducive for high performance and fault tolerance, making this machine a promising solution for the safety-critical applications.

Delta-connected winding is less adopted in industrial applications due to presence of the triplen EMF harmonics and resultant zero sequence current under healthy condition. Investigations of performance for delta-connected PMASynRM under various fault conditions are almost absent from the literature. However, as reported in many literatures, three-phase wye-connected machine cannot operate with three-phase inverter in the one-phase open-circuit fault condition because the two remaining active phases are dependent on each other. Therefore, the neutral point of the wye connection has to be accessible and connected to the mid-point of the drive's dc-bus or to an additional leg, which increases the system cost and reduces the reliability of the overall

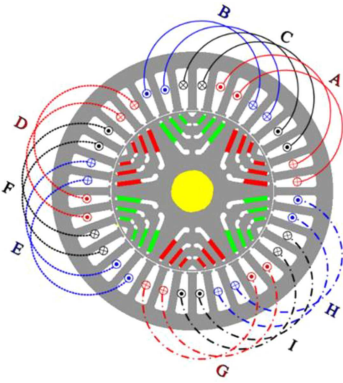

Fig. 1 PMASynRM with segregated windings

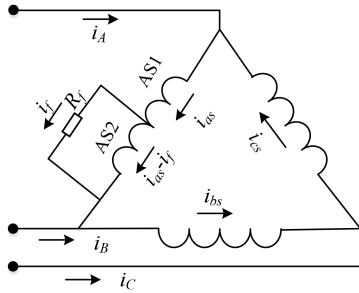

Fig. 2 Schematic of the delta-connected PMASynRM with turn fault in single phase

system. Delta-connected winding has better torque capability under one-phase open-circuit fault condition in induction machines [14]. In addition, it will be shown that the delta-connected winding yields low fault current under turn fault condition and consequently lower hot spot temperature which is beneficial for improved lifetime of the machine under this fault.

Therefore, this paper will investigate the delta-connected winding PMASynRM with the same machine topology reported in [13]. Firstly, an equivalent model of delta-connected winding with inter-turn short-circuit will be established for better insight of the fault behaviour. The performances of the triple redundant PMASynRM with the delta- and wye-connected windings will be comprehensively compared under healthy and various fault conditions, including open circuit, inter-turn short-circuit and terminal short-circuit. Additionally, because temperature is a key limiting factor for post-fault operation, the highest hotspot temperature under the worst condition will be analysed and compared.

2 Equivalent model of delta-connected PMASynRM with turn fault

For the convenience of the discussion, a turn fault is assumed to occur in ABC set, and the influence between different three-phase sets is neglected. Therefore, only one three-phase under the fault condition needs to be considered. The circuit schematic of the three-phase delta-connected winding ABC with a turn fault in phase A is shown in Fig. 2. Phase A is divided into two sub-windings denoted by AS1 (healthy part) and AS2 (faulty part). Some further simplifications are made for derivation of the influence of key parameters on the inter-turn fault current. (i) Stator core are infinitely permeable and magnetic saturation is neglected; (ii) Stator slotting effect is ignored. The fault ratio μ is defined as the ratio of the number of short-circuited turns to the total number of turns in phase A.

The theoretical analysis for establishing the equivalent model for the delta-connected PMASynRM with inter-turn fault in one phase is based on the method described in [15].

It can be shown that based on the foregoing assumption the voltage, v_{as2} , and the flux linkage, λ_{as2} , of the SC winding AS2 for the delta-connected PMASynRM in the dq frame are given by

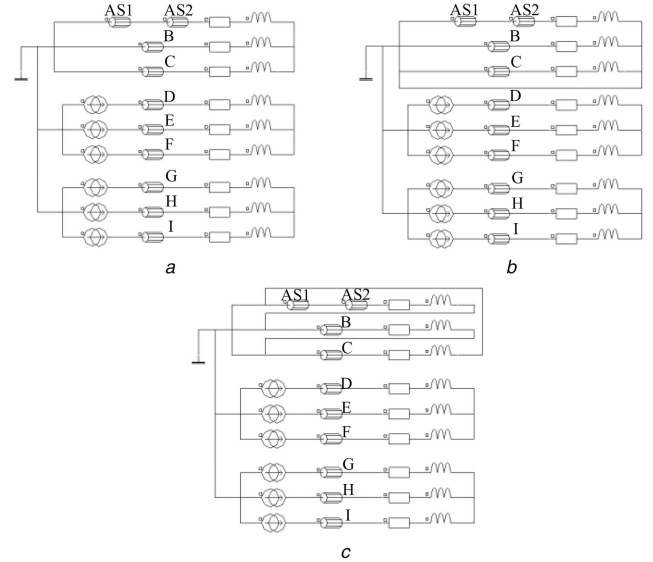

Fig. 3 Schematic of circuit under One three-phase SC (a) Without neutral line, (b) With neutral line, (c) Delta-connected

$$v_{as2} = R_f i_f = \mu R_s [i_d \cos(\theta) - i_q \sin(\theta) + i_o - i_f] + \frac{d\lambda_{as2}}{dt} \quad (1)$$

$$\lambda_{as2} = \mu(L_{ls} + L_{md})i_d \cos(\theta) - \mu(L_{ls} + L_{mq})i_q \sin(\theta) + \mu L_{ls} i_o + \mu \lambda_m \cos(\theta) - \mu(L_{ls} + \mu L_{aa})i_f \quad (2)$$

Similarly, the voltage and flux linkage of the short-circuited AS2 winding for the wye-connected machine in the dq frame are obtained by [15]

$$v_{as2} = R_f i_f = \mu R_s [i_d \cos(\theta) - i_q \sin(\theta) - i_f] + \frac{d\lambda_{as2}}{dt} \quad (3)$$

$$\lambda_{as2} = \mu(L_{ls} + L_{md})i_d \cos(\theta) - \mu(L_{ls} + L_{mq})i_q \sin(\theta) + \mu \lambda_m \cos(\theta) - \mu(L_{ls} + \mu L_{aa})i_f \quad (4)$$

where R_f is the fault resistance; i_f is the fault circulating current; i_o is the zero sequence current; i_d, i_q are the d - and q -axis currents; R_s is the phase resistance; L_{ls} is stator slot leakage; L_{aa} is the phase A self-inductance; λ_m is the phase flux linkage generated by the permanent magnets; L_{md}, L_{mq} are the main d - and q -axis inductances; θ is the rotor angle (electrical) with respect to phase A winding.

It can be observed from (1) and (2) of the delta-connected winding and (3) and (4) of the wye-connected winding that the only difference is the zero sequence current i_o . FE analysis will be used to assess the influence of zero sequence current on the flux linkage λ_{as2} .

Two different winding configurations are used in FEA as shown in Figs. 3a and b. In both cases, the DEF and GHI three-phase sets are wye connected and operate in the healthy condition and a terminal SC is applied to the wye-connected three-phase set ABC. However, Fig. 3b differs from Fig. 3a in that the ABC set is terminal short circuit with a neutral line. This will result in circulation of zero sequence current, which is equivalent to that of Fig. 3c in which the delta-connected three-phase set ABC is terminally short circuited.

In the simulations, the AS2 part is not short circuited, so the turn-fault current i_f is 0. The other two healthy three-phase sets have the same mutual effect on the ABC set. Hence, the difference of the turn flux linkage λ_{as2} between the two winding configurations is mainly due to the zero sequence current according to (1)–(4). The turn flux λ_{as2} under the two cases is compared in Fig. 4. As seen, the turn flux λ_{as2} of the machine with the neutral line is smaller than that of the machine without the neutral line. It follows that the zero sequence current helps nullify the turn flux

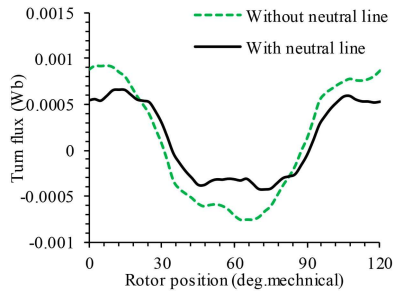

Fig. 4 Neutral line on the effect of turn flux

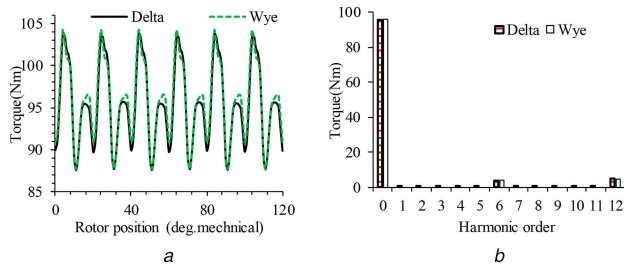

Fig. 5 Comparison of output torque between wye- and delta-connected machine

Table 1 Comparison of performance at rated operation

Winding configuration	Wye	Delta	Difference, %
average torque N m	95.66	95.23	-0.45
torque ripple, %	17.19	17.12	-0.41
copper loss, W	1228.62	1241.37	1.04
iron loss, W	57.98	58.20	0.38
efficiency, %	96.89	96.84	-0.05

Table 2 Comparison of performance under F1

Winding configuration	Wye	Delta_S1	Delta_S2
average torque, N m	54.57	86.85	76.96
torque ripple, %	28.09	31.69	17.96

linkage and hence further reduce the induced voltage and circulating current in the faulted turn.

3 Healthy performance

The delta- and wye-connected PMASynRMs are required to have the same fundamental MMF, the line current and slot fill factor. Hence, the number of turns per coil, the conductor size and the phase resistance in the delta-connected PMASynRM are proportionally increased, while the fundamental phase current is decreased. The design details and specification of the wye-connected PMASynRM are given in [13].

Under no-load condition, the delta-connected PMASynRM has extra triplen harmonic components in the line-to-line back EMF compared with the wye-connected PMASynRM. In the rated operation (rated torque at the base speed), the phase current of the wye-connected PMASynRM is assumed to be sinusoidal through inverter control, while the phase current of the delta-connected PMASynRM contains the fundamental and triplen harmonics. The third-harmonic component in the phase currents, known as zero sequence current, is identical in phases A, B and C with the magnitude around 10% of the fundamental current and results from the triplen harmonics in the line-to-line back EMF as well as the interaction of the rotor saliency with the fundamental component of phase currents.

In the delta-connected PMASynRM, apart from the same torque ripple with the wye-connected PMASynRM, the third-harmonic phase current (neglecting higher order triplen harmonics) will interact with the EMF harmonic to generate torque ripple.

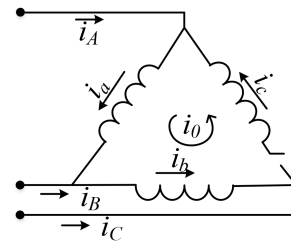

Fig. 6 Schematic of one phase OC scenario

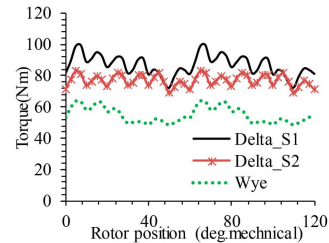

Fig. 7 Comparison of torque waveforms under F1

However, only the triplen EMF harmonics interacts with the zero sequence current, generating $3k$ order of torque ripple.

The torque waveforms and their spectra of the delta- and wye-connected machines at the rated torque and base speed are compared in Fig. 5 and the key performance indicators in Table 1. As can be seen, the fundamental torque of the delta-connected PMASynRM (95.23 N m) is 0.45% lower than that of the wye-connected PMASynRM (95.66 N m). Main torque ripple harmonics of the two machines are 6th and 12th. Besides, there is very little increase of the $3k$ order torque ripples of the delta-connected PMASynRM because of relatively small triplen EMF harmonics.

Hence, the zero sequence current of the delta-connected PMASynRM has little effect on the output torque, albeit it will increase the copper loss by 1%. The performances under peak torque and base speed are very similar to that obtained from the rated torque and base speed except for the more obvious partial saturation due to the zero sequence current.

4 Fault performance

The performances of the two winding configurations under various fault conditions at the rated torque and base speed are compared. Fault conditions considered in this paper are F1: one-phase open-circuit, F2: one three-phase open-circuit, F3: one-turn short circuit, F4: one-turn short circuit with three-phase terminal short circuit. One three-phase terminal short-circuit fault is not considered separately because it has very similar steady-state performances to F4. Besides, for the sake of discussion, all the faults are assumed to occur in the ABC three-phase winding.

4.1 One-phase open-circuit fault

It has been known that in the wye-connected machine, a three-phase set cannot produce continuous torque when one phase is open-circuited. For the delta-connected PMASynRM, if one connection to the inverter leg is open circuited, the faulty three-phase set cannot operate either. However, if an open circuit occurs in the phase connection as shown in Fig. 6, the currents in phases A and B can still be controlled by the inverter to produce continuous torque. For the same line currents, the magnitude of i_a, i_b will $\sqrt{3}$ be times. This is denoted as Delta_S1. Alternatively, the line currents will be $1/\sqrt{3}$ times if the magnitude of i_a, i_b is kept the same. This is denoted as Delta_S2. The resultant torque waveforms and average torques under F1 between the wye- and delta-connected PMASynRM with the remedial actions Delta_S1 and Delta_S2 are compared in Fig. 7 and Table 2.

It can be observed that the average torque of Delta_S1 and Delta_S2 are both larger than that of the wye-connected PMASynRM because the remaining two active phases in the delta-

Table 3 Comparison of performance under F3

Winding configuration	Wye	Delta_C1	Delta_C2
average torque, N m	54.57	55.90	54.19
torque ripple, %	28.09	33.32	36.68
copper loss, W	819.0	977.2	925.4
total iron loss, W	56.93	51.61	52.43
efficiency, %	96.31	95.79	95.87

Table 4 Comparison of performance under F3

Winding configuration	Wye	Delta
RMS of turn current, A	726.70	694.43
RMS turn fault current normalised to/rated, pu	8.71	14.44
turn loss, W	857.6	1354.8
average torque, N m	84.64	85.89
torque ripple, %	37.03	33.50

connected machine can be independently controlled and used to produce torque. Additionally, with the remedial action Delta_S2, the torque ripple is much smaller than that in the wye-connected PMASynRM. This is because the negative-sequence rotating component of MMF has been eliminated by the angular phase shift of currents [14].

4.2 One three-phase open-circuit fault

There are two possible cases of the delta-connected PMASynRM under one three-phase open-circuit fault. One is named as Delta_C1 in which the three-phase inverter is disconnected, and the other is denoted as Delta_C2 in which the three stator phases are disconnected.

In Delta_C1, the faulted three-phase set has loop current which is generated by the triplen harmonics in the line-to-line back EMF and the mutual coupling between the healthy phases and the faulty phases. The phase currents of the faulted three-phase set are both zero in Delta_C2 and in the wye-connected PMASynRM. The remaining two healthy three-phase sets of the wye- and delta-connected PMASynRMs are excited as usual. Under F2 of the delta-connected PMASynRM, however, although the line currents of the remaining two three-phase sets are kept the same by the inverter control, the phase currents are more distorted to the unbalance and mutual coupling, leading to increased copper loss and torque ripple compared with the wye-connected PMASynRM under F2. Table 3 compares the main performance indicators under F2.

As observed, the steady-state performance of the wye-connected PMASynRM under F2 is the same as that under F1. The delta-connected PMASynRM has similar average torque but with larger torque ripple, higher copper loss, and slightly lower efficiency compared with the wye-connected PMASynRM under F2.

4.3 One-turn short-circuit fault

The steady-state performance indicators under one turn short circuit (F3) of the wye- and delta-connected PMASynRM are shown in Table 4. It can be observed that the normalised RMS turn-fault current and the resultant copper loss in the faulted turns of the delta-connected PMASynRM are much higher than those of the wye-connected PMASynRM. Additionally, the average torque between two winding configurations is similar while the torque ripple of the delta-connected machine is lower.

4.4 One-turn short-circuit with three-phase terminal short-circuit

The extremely large fault current in F3 is unsustainable. However, upon detection of the fault, three-phase terminal short circuit should be applied through the inverter to nullify the flux linkage in the faulted turn and hence reducing the fault current. This is referred to as F4. Thus, performances under F4 are most critical for

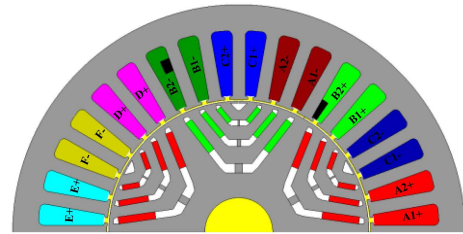
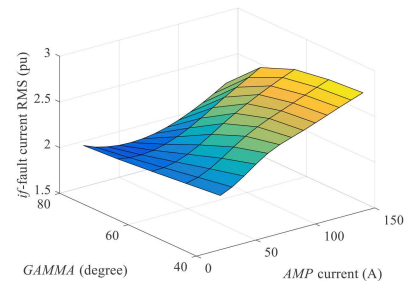
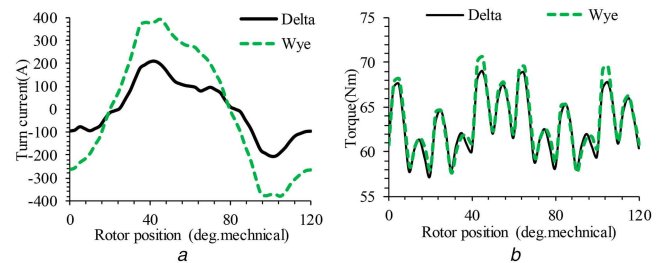
**Fig. 8** Cross section of SC turn in B2 coil of PMASynRM**Fig. 9** Variation of turn fault current in B2 coil with amplitude and gamma angle of currents in healthy sets**Fig. 10** Comparison of performance under F4

(a) Currents in faulted turns (b) Output torque

post-fault operation and the resultant the maximum temperature under F4 between the wye- and delta-connected PMASynRMs will be assessed and compared.

Due to the mutual coupling between the two healthy three-phase sets and the faulty three-phase set, the fault current is dependent on the location of the fault in the six possible coils A1, A2, B1, B2, C1 and C2 as illustrated in Fig. 8. It has been shown in [13], when the SC turn is located in B2 coil marked by the black square in Fig. 8, the resultant current of the wye-connected PMASynRM is the highest. Similar scan of the turn fault current when the fault occurs in six coils of the delta-connected PMASynRM is performed by FEA. For each fault location, the amplitude and GAMMA (torque) angle of the current vector in the two healthy three-phase sets are varied over [0 A, 150 A] and [40°, 80°]. It has been found that the fault in B2 coil is also the worst. The RMS fault current variation with the amplitude and GAMMA angle of the currents in the two healthy three-phase sets is shown in Fig. 9.

Hence, the black squares in Fig. 8 illustrate the worst fault condition under F4 of the delta-connected PMASynRM.

The resultant torque waveforms and performance indicators of the wye- and delta-connected PMASynRMs under F4 are shown in Fig. 10 and Table 5, respectively. In addition, Table 6 compares the average temperature and hotspot temperature of different parts under the rated healthy operation and F4 between the two winding configurations. These temperatures are obtained by establishing representative thermal model of the machine under study as described in [16]. Both thermal models of two winding configurations have same initial and ambient temperatures.

It can be observed that the average torque and torque ripple of the wye- and delta-connected PMASynRM are very similar. However, the RMS turn fault current of the delta-connected machine (122.26 A, 2.54 pu) is significantly lower than that of the wye-connected machine (266.25 A, 3.20 pu). This is due to the zero sequence current which tends to reduce the flux linkage of the

Table 5 Comparison of performance under F4

Winding configuration	Wye	Delta
RMS of turn current, A	266.62	122.26
RMS turn fault current normalised to rated, pu	3.20	2.54
average torque, N m	63.37	62.92
torque ripple, %	20.45	18.76

Table 6 Comparison of temperature under healthy condition and F4

Temperature	Wye	Delta	
Healthy condition	Rotor, °C	154	155
	Stator tooth, °C	153	154
	Stator yoke, °C	129	129
	Copper, °C	162	163
Fault condition	Hot spot, °C	251	186

short circuited turn in the delta-connected PMASynRM. Thus, while the two design variants have very similar temperature rise under healthy conditions, the hot spot temperature of the delta-connected PMASynRM (186°C) is much lower than that of the wye-connected PMASynRM (251°C).

5 Summary

This paper compares the performance of a triple redundant, nine-phase PMASynRM with wye- or delta-connected windings under healthy and fault conditions. It has been shown that they have very similar performances in healthy operations, although the delta-connected PMASynRM has extra zero sequence current which leads to increase in the copper loss by 1%. The steady-state performance of the delta-connected PMASynRM is slightly worse than that of the wye-connected PMASynRM under three-phase open-circuit and one-turn short-circuit fault. However, it has much higher average torque and smaller torque ripple compared with the wye-connected PMASynRM under one-phase open-circuit fault. It is also shown that the zero sequence current in the delta-connected machine reduces the flux linkage of the short-circuited turns, resulting in significantly lower turn fault current and lower hotspot temperature compared with the wye-connected PMASynRM. This leads to better fault tolerance.

6 References

- [1] Bianchi, N., Pr , M.D., Grezzani, G., *et al.*: 'Design considerations on fractional-slot fault-tolerant synchronous motors'. IEEE Int. Conf. on Electric Machines and Drives, San Antonio, TX, USA, 2005, pp. 902–909
- [2] Welchko, B., Jahns, T.M., Hiti, S.: 'IPM synchronous machine drive response to a single-phase open circuit fault', *IEEE Trans. Power Electron.*, 2002, **17**, pp. 764–771
- [3] Sun, Z., Wang, J., Howe, D., *et al.*: 'Analytical prediction of the short-circuit current in fault-tolerant permanent-magnet machines', *IEEE Trans. Ind. Electron.*, 2008, **55**, pp. 4210–4217
- [4] Bianchi, N., Pre, M.D., Bolognani, S.: 'Design of a fault-tolerant IPM motor for electric power steering', *IEEE Trans. Veh. Technol.*, 2006, **55**, pp. 1102–1111
- [5] Vaseghi, B., Takorabet, N., Caron, J.P., *et al.*: 'Study of different architectures of fault-tolerant actuator using a two-channel PM motor', *IEEE Trans. Ind. Appl.*, 2011, **47**, pp. 47–54
- [6] Spargo, C.M., Mecrow, B.C., Widmer, J.D., *et al.*: 'Application of fractional-slot concentrated windings to synchronous reluctance motors', *IEEE Trans. Ind. Appl.*, 2015, **51**, pp. 1446–1455
- [7] Spargo, C.M., Mecrow, B.C., Widmer, J.D.: 'Higher pole number synchronous reluctance machines with fractional slot concentrated windings'. 7th IET Int. Conf. on Power Electronics, Machines and Drives (PEMD 2014), Manchester, UK, 2014, pp. 1–6
- [8] Ishak, D., Zhu, Z., Howe, D.: 'Comparison of PM brushless motors, having either all teeth or alternate teeth wound', *IEEE Trans. Energy Convers.*, 2006, **21**, pp. 95–103
- [9] Wang, J., Atallah, K., Zhu, Z.-Q., *et al.*: 'Modular three-phase permanent-magnet brushless machines for in-wheel applications', *IEEE Trans. Veh. Technol.*, 2008, **57**, pp. 2714–2720
- [10] Parsa, L., Toliyat, H.: 'Fault-tolerant interior-permanent-magnet machines for hybrid electric vehicle applications', *IEEE Trans. Veh. Technol.*, 2007, **56**, pp. 1546–1552
- [11] Levi, E.: 'Multiphase electric machines for variable-speed applications', *IEEE Trans. Ind. Electron.*, 2008, **55**, pp. 1893–1909
- [12] Barcaro, M., Bianchi, N., Magnussen, F.: 'Analysis and tests of a dual three-phase 12-slot 10-pole permanent-magnet motor', *IEEE Trans. Ind. Appl.*, 2010, **46**, pp. 2355–2362
- [13] Wang, B., Wang, J., Griffio, A.: 'A fault tolerant machine drive based on permanent magnet assisted synchronous reluctance machine'. Energy Conversion Congress and Exposition (ECCE), Milwaukee, WI, USA, 2016
- [14] Sayed-Ahmed, A., Demerdash, N.: 'Fault-tolerant operation of delta-connected scalar-and vector-controlled AC motor drives', *IEEE Trans. Power Electron.*, 2012, **27**, pp. 3041–3049
- [15] Sen, B., Wang, J., Lazari, P.: 'A detailed transient model of Interior permanent magnet motor accounting for saturation under stator turn fault', Energy Conversion Congress and Exposition (ECCE), Denver, CO, USA, 2013, pp. 3548–3555
- [16] Wang, J., Wang, W., Atallah, K., *et al.*: 'Design of a linear permanent magnet motor for active vehicle suspension'. Electric Machines and Drives Conf., 2009. IEMDC'09. IEEE Int., Miami, FL, USA, 2009, pp. 585–591