

This is a repository copy of *A Conceptual Framework of Business Model Emerging Resilience*.

White Rose Research Online URL for this paper:  
<http://eprints.whiterose.ac.uk/104806/>

Version: Accepted Version

---

**Conference or Workshop Item:**

Goumagias, Nik, Fernandes, Kiran, Cabras, Ignazio et al. (6 more authors) (2016) A Conceptual Framework of Business Model Emerging Resilience. In: 32nd European Group for Organization Studies (EGOS) Colloquium, 07-09 Jul 2016, Italy.

---

**Reuse**

Items deposited in White Rose Research Online are protected by copyright, with all rights reserved unless indicated otherwise. They may be downloaded and/or printed for private study, or other acts as permitted by national copyright laws. The publisher or other rights holders may allow further reproduction and re-use of the full text version. This is indicated by the licence information on the White Rose Research Online record for the item.

**Takedown**

If you consider content in White Rose Research Online to be in breach of UK law, please notify us by emailing [eprints@whiterose.ac.uk](mailto:eprints@whiterose.ac.uk) including the URL of the record and the reason for the withdrawal request.

# A Conceptual Framework of Business Model Emerging Resilience

Nikolaos Goumagias<sup>a\*</sup>, Kiran Jude Fernandes<sup>a</sup>, Ignazio Cabras<sup>b</sup>, Feng Li<sup>c</sup>, Jianhua Shao<sup>c</sup>, Sam Devlin<sup>d</sup>, Victoria Hodge<sup>d</sup>, Peter Cowling<sup>d</sup>, Daniel Kudenko<sup>d</sup>

<sup>a</sup> Durham University Business School, Mill Hill Lane, Durham, DH1 3LB, UK

<sup>b</sup> Newcastle Business School, Newcastle City Campus, 2 Ellison Pl, Newcastle upon Tyne, Tyne and Wear NE1 8ST

<sup>c</sup> Cass Business School, City University London, 106 Bunhill Road, London, EC1Y 8TZ, UK

<sup>d</sup> University of York, York Centre of Complex System Analysis (YCCSA), Ron Cooke Hub, Heslington YO10 5GE, UK

## Abstract

In this paper we introduce an environmentally driven conceptual framework of Business Model change. Business models acquired substantial momentum in academic literature during the past decade. Several studies focused on what exactly constitutes a Business Model (role model, recipe, architecture etc.) triggering a theoretical debate about the Business Model's components and their corresponding dynamics and relationships. In this paper, we argue that for Business Models as cognitive structures, are highly influenced in terms of relevance by the context of application, which consequently enriches its functionality. As a result, the Business Model can be used either as a *role model* (benchmarking) or a *recipe* (strategy). For that purpose, we assume that the Business Model is embedded within the economic (task) environment, and consequently affected by it. Through a typology of the environmental impact on the Business Model productivity, we introduce a conceptual framework that aims to capture the salient features of Business Model emergent resilience as reaction to two types impact: productivity constraining and disturbing.

*Keywords: Business Model, Framework, Business Environment, Resilience*

## 1. Introduction

In September 2015, the Environmental Protection Agency (EPA) of the US, investigated a number of Volkswagen (VW) vehicles that were sold in the national market. They found that the company had implemented a software programme

---

\* Corresponding Author: Nikolaos Goumagias ([nikolaos.d.goumagias@durham.ac.uk](mailto:nikolaos.d.goumagias@durham.ac.uk))

Co-authors' Contact Details: Kiran J. Fernandes ([k.j.fernandes@durham.ac.uk](mailto:k.j.fernandes@durham.ac.uk)), Ignazio Cabras ([ignazio.cabras@northumbria.ac.uk](mailto:ignazio.cabras@northumbria.ac.uk)), Feng Li ([Feng.Li.1@city.ac.uk](mailto:Feng.Li.1@city.ac.uk)), Sam Devlin ([sam.devlin@york.ac.uk](mailto:sam.devlin@york.ac.uk)), Peter Cowling ([peter.cowling@york.ac.uk](mailto:peter.cowling@york.ac.uk)), Daniel Kudenko ([daniel.kudenko@york.ac.uk](mailto:daniel.kudenko@york.ac.uk))

(defeat device) in 482,000 cars' engine that affected the performance metrics and consequently carbon dioxide emissions. VW's CEO Michael Horn admitted, "... breaking the trust" of their customers, and launched an internal inquiry. The company reacted by recalling millions of cars around the world, resulting in £4.8bn in costs, excluding corresponding fines. However, the entire car-manufacturing sector is affected by the scandal. Several governments (German, UK, and US) announced a series of investigations and various regulatory reforms for future implementation. The impact to the global diesel-engine car manufacturing market was very negative, because up to that point car manufacturers, in collaboration with governments, invested on and promoted diesel engines as the more environmental friendly alternative (Russell 2015).

Negative environmental externalities challenge constantly a company's performance, strategic position, and structure. Companies react to these externalities through innovation, and implementation of new capabilities and routines (Dosi 2000). Those actions have to be desirable, proper and appropriate within the societal system, to increase the organisational legitimacy, and consequently increase the access to resources (Suchman 1995). The organisational aim is to become more *resilient* against the environmental factors so as to be able to measure "... the magnitude of disturbance that the system can tolerate and still persist" (Mamouni Limnios et al. 2014: p. 104).

However, economic organisations' reactions to those vary significantly in both magnitude and direction. For instance, large enterprises possess a significant array of resources, political power, and complementary assets. As a result, organisations do not only react to environmental changes, but also to enact on their environment in a bi-directional relationship (Geels 2014). However, organisational inertia, path dependencies (Sydow et al. 2009), and lock-in effects (Arthur 1989) prevent companies from implementing timely and relevant reactions to environmental shifts, rendering the companies reluctant to change. The inertia become even stronger when the organisation's core competencies are questioned (Scarborough 1998).

Consequently, economic organisations co-evolve with the environment. Co-evolution is described as the systematic "... interaction between the forms of economic organization, social and political institutions, and technical change" (Dosi & Marengo

2007: p 491). However, the organisation's exact response mechanism is debatable in academic literature. On one hand, there are environmental factors that push towards homogeneity and isomorphism within sectors and industries. On the other hand, firm-specific strategies lead towards diversity of forms and structures (Astley & Van de Van 1983). Lewin & Volberda (2003) argue that the dichotomy between these two approaches is superficial. Adaptation (passive change) adopts a top-down approach on organisational populations, which passively respond to externalities, while selection (active change) revolves around firm specific strategies. The debate between active and passive change to negative externalities is reflected in the organisational resilience and change literature. Passive adaptation leads to defensive resilience, while active change leads to offensive resilience (Mamouni Limnios et al. 2014). In this paper we will focus on defensive resilience. For consistency reasons we will use the term "emergent resilience", to avoid confusion with strategic management literature.

Lewin & Volberda (2003) also argue that one-sided approaches are no longer productive in explaining co-evolution, and that a multidimensional approach is more appropriate. In this paper, we move a step forward, and argue that the dichotomy is partially caused by the scholars' choice of the unit of analysis, which poses restrictions to the conceptualisation of the organisation's relationship with the environment. In other words, the choice of the unit of the analysis explicitly draws the line between the organisation and its environment. The majority of academic literature uses the firm, or the population of firms, as the focal point. Consequently, every entity, activity, or stakeholder that lies outside the direct control of the organisation, is considered as part of the broader environment. On the other hand, the Business Model, as a model of the organisation's value creation and delivery process, spans the boundaries of a single firm, or industry, by internalising the relationships (direct or indirect) of the organisation with other entities.

In this paper we aim to capture the salient features of organisational change, as a reaction to environmental changes. For that purpose, based on longitudinal historic analysis, we develop a framework that allows us to evaluate an industry's business model archetypes' resilience. The paper is structured as follows. In Section 2 we explore the BM literature as a means of capturing and analysing organisational diversity. In Section 3, we discuss the literature of organisational resilience and

approaches in resilience measurement. In sections 4, based on theoretical and empirical evidence, we develop a framework of the environmental topology using the impact of environmental shifts as the main dimension. In section 5, we develop a process of Business Model reconfiguration into Business Model Archetypes (Building blocks of Business Models) and their respective array of characteristics. The array of characteristics is used, via a historical event analysis, to measure the corresponding resilience in section 6. We also include a case study of the international biopharmaceutical industry to demonstrate the applicability of the framework. Finally, in section 7, we conclude our analysis.

## **2. Business Models and Organisational Change**

How can organisational change, as a reaction to environmental shifts, be reflected on its Business Model and how do Business Models change through time? During the last decade, the term “Business Model” (BM hereafter) emerged as a focal point of analysis among academics and practitioners. The increasing impact of rapidly growing and technologically intensive industries on economies and societies, such as biotechnology, information and telecommunication, and creative industries, challenged the traditional systemic approaches of organisational and industrial research, shifting the focus on the increasing complexity and embeddedness of their organisational structure.

However, a widely accepted definition of BM, along with the corresponding components, is far from convergent. Numerous definitions have been suggested that vary according to the scholars’ point of view e.g. organisational, strategic, technology oriented (Wirtz et al. 2015), although definition and design of BM tend to be based on three main dimensions: value sensing, creation, and capturing (Zott et al. 2011).

According to Wirtz et al. (2015), the literature about BM revolves into mainly two silos: *static*, and *dynamic* approaches. Demil & Lecocq (2010) aim to capture the features of this dichotomy. They argue that static approaches are useful for descriptive purposes and can potentially support managers in identifying and communicating their BM to others. However, static and discretionary representations of BM somehow fail to capture the dynamic process of BM change in full: this might affect managers’ decision making processes towards transforming certain aspects of their BM, aligning the BM with a corresponding organisational strategy. In response,

Mintzberg & Waters (1985) introduce a strategic spectrum of approaches that unfold between deliberation and passive emergence as a response to external forces (absence of intention). In addition, Demil & Lecocq (2010b) indicate an organisational *Penrovian* systemic structure (open system) in which BMs evolves (or change) in response to external and internal factors. External factors, or *jolts*, may disrupt organisations' usual functioning abruptly, repositioning BMs within organisations with regard to threats and opportunities these might face.

Change can be either emergent, as reaction to environmental change, or deliberate, as a proactive strategic decision process (Mintzberg & Waters, 1985). In this case, BMs are at the centre of any organisational change between deterministic and passive evolution, and intentional and purposeful strategic change (Astley & Van de Van 1983). In contrast, Baden-Fuller & Morgan (2010) tend to circumvent the debate between deliberate and emergent BM change, describing BMs as cognitive maps of conceptual frameworks, which work as recipes or role models that can guide change (if deliberate) or track changes (if emergent). In this view, the components of any BM can re-aligned or re-arranged via exploration and/or exploitation (Sosna et al. 2010).

As cognitive structures, BMs transcend the narrow boundaries of a given organisation, and even the boundaries of whole industries, although there are homogenous BMs (in terms of components) that operate in different industries. As a result, the BM market-based evolutionary inspired selection mechanism, which dictates the emergence of new BMs, moves from *organisational change* toward *BM change*. More specifically, selection processes within evolutionary driven organisational change are identifiable by observing market entry/exit rates, and by investigating populations within organisational ecosystems (thus via organisational classifications- (Astley & Van de Van 1983). Conversely, as cognitive concepts, BMs are selected based on their relevance (Baden-Fuller & Morgan 2010). As result, the importance of BMs re-emerges via environmental changes, with the BM concept rising as the reflection and realisation of organisational forms derived from organisational theory.

In this paper, we base our investigation on the organisational perspective of the BM (Osterwalder & Pigneur 2010) in the attempt to provide a cross-fertilisation between BM literature and the rich literature of environmentally driven organisational change

(Levinthal 1991; Astley & Van de Van 1983). We argue that BMs, as cognitive structures, can potentially be used to bridge the debates about organisational change, deliberate or emergent, reactive or proactive. We use environmental changes as a reference point in order to establish causal nexus between BM components and environmental characteristics (Emery & Trist 1965). In doing so, we introduce an environmentally driven typology of BM environmental emergent resilience (Demil & Lecocq 2010).

### **3. Organisational Resilience**

Resilience literature stems from the seminal work of Holling (1973), who explored the resilience of ecological systems. His work attracted considerable multidisciplinary attention, particularly on behalf of evolutionary and ecological economics (Brand 2009; Derissen et al. 2011). Holling (1973) differentiates between resilience and stability. The latter was later adopted by the engineering perspective of resilience, where it is described as "... a measure of a system's persistence and the ability to absorb disturbances and still maintain the same relationships between system entities" (Bhamra et al. 2011: p. 5380). Consequently, the engineering-based view of resilience is more closely related to robustness building strategies, as opposed to complexity absorption, and complexity reduction (Lengnick-Hall 2005).

Strategic management adopts an implicit relationship with organisational resilience, by focusing on the company's actions to adapt to environmental complexity (Lamberg & Parvinen 2003). Scholars adopt either an inside-out approach to organisational adaptation focusing on leadership and decision making, or an outside-in one examining creation and defence of strategic positioning within an industrial regime (Hoskisson et al. 1999). However, resilience does not appear as part of the firm's strategy, but rather as a heuristic explanation of why certain companies fail, while others succeed (Mamouni Limnios et al. 2014).

Organisational resilience as a response to the environmental complexity, to retain or improve environmental fitness, is a relatively new silo in resilience literature (Lengnick-Hall & Wolff 1999). According to Holland (1975), organisations can be treated as adaptive systems which reflect the complexity of the environment that they

operate under certain restrictions (Varela et al. 1991). Consequently, economic organisations can be considered as representational schemata, or interpretive systems (Weick 1979) which are capable of enactment on the environment, which sets organisations apart from natural systems (Weber 1964). Complexity has two dimensions: a) the number of systemic elements, and b) the number of their interactions (Boisot & Child 1999). To handle such evolving complex systems, Schuster (1996) captures it phylogenetically. Consequently, BMs (elements, components, and their relationship) on one hand can be regarded as heuristic approximations of an organisation's environmental fitness, and through phylogenetically classifying those; it is feasible to capture the complexity they reflect.

Companies adopt three distinct strategies to respond to the environmental complexity, and increase their fitness: a) complexity absorption (Boisot & Child 1999), b) complexity reduction (Boisot & Child 1999), and c) robust transformation (Lengnick-Hall 2005). According to Boisot & Child (1999), complexity reduction strategy is achieved through thorough understanding of the environment, and via this understanding enact on the environment to shield the organisation from environmental jolts. Consequently, according to (DiMaggio & Powell 1983), and in terms of organisational structure, companies that adopt complexity reduction are expected to conform to three kinds of institutional pressures: a) coercive isomorphism dictated by regulations, b) normative pressures dictated by professional standards, and c) mimetic pressures based on which companies model themselves against other organisations. Particularly the last pressure is important in our analysis, because BMs as models (Baden-Fuller & Morgan 2010) can be used strategically by organisations to respond to these pressures. On the other hand, complexity absorption is considered a risk hedging strategy (Boisot & Child 1999). When understanding of the environmental complexity is fogged, companies respond via the development of a portfolio of competencies and capabilities, routines and behaviours in order to *satisfice* rather than *optimise* (Nelson & Winter 1982). Consequently, the company can acquire certain *plasticity* and respond effectively to unanticipated jolts. However, to the best of our knowledge, further research is required considering the contingencies among the various routines, capabilities and competencies. On the other hand, Lengnick-Hall (2005) identified a third response to environmental shifts particularly when they are unanticipated (complexity reduction), or the company lack



the slack capabilities to respond (complexity absorption), namely robust transformation. According to this strategy an organisation deliberately respond to new and changing environmental conditions by capitalising changes via creation of new capabilities and routines. As a result, the company does not move from one equilibrium to another, but operates within a constant flux (Lengnick-Hall 2005). The goal of the organisations is, as a result, the development and sustaining of *resilience capacity*.

Resilience capacity is a "...multidimensional construct at the organisational level that describes collective behaviours and attitudes" (Lengnick-Hall 2005: p. 749). The resilience is reflected on the organisation's routines that emerge as an answer to uncertainty. Focusing on the organisational aspects of resilience capacity, as opposed to the psychological aspects, scholars attempted to assess and measure resilience capacity (Mallak 1998; Rose 2004). The majority of articles that aim to estimate systemic resilience focus on supply chains (Iakovou et al. 2007; Klibi & Martel 2012). However, the majority of resilience literature does focus only on one dimension of environmental impact: shocks, and disasters along with the companies' ability to rebound from the shock (Annarelli & Nonino 2014). Mamouni Limnios et al. (2014) considers another dimension of organisational resilience: desirability, and proposes a typology in the form of Resilience Architecture Framework.

#### **4. Assumptions and Methodology: The environmental space**

In their seminal work, Emery & Trist (1965), argue that for a comprehensive development of organisational behaviour, it is important for scholars to explore, in addition to the reciprocal relationship between the organisation and the environment, and the processes taking place within the organisation, *the causal texture of the environment*. The authors use the term "causal texture" to describe the geometry of the environmental elements and their interdependencies. They move one step further and develop a typology of four ideal types of environmental spaces. The four types can change both horizontally (from one type to another) and vertically (coexistence of types). The impact of the environmental textures to the organisation depends on the organisation's attributes (size, structure, etc).

According to Emery & Trist (1965), the first type of environmental texture (*placid randomised environment*) is simple in geometry. Positive and negative externalities are randomly distributed. The distribution remains stable through time. The notion of free market corresponds to this type of environmental texture. This type of environmental texture supports increased number of small in size organisations. This attribute becomes progressively weaker as the complexity of the texture increases. The second type, namely *placid clustered environment*, is characterised by clustered positive and negative externalities, albeit still randomly distributed. Imperfect competition corresponds to this type of environmental texture. Environmental awareness becomes important under these environmental conditions and consequently, organisations are called to develop strategies to navigate through the environment. The third type of environmental texture is called distributed reacted environment. Oligopolistic market corresponds to this environmental structure. Organisations become aware of other organisations and their decisions have an impact on strategic level.

The fourth type of environment (turbulent field), corresponds to a dynamically changing geometry which stems not only from the organisations operating within the environment, but from the environment itself. Emery & Trist (1965) use the term: “the ground is in motion” to describe the dynamics of this environmental texture which stem from interaction among the environmental elements, resulting in nonlinear, random results. This implies a strong increase in uncertainty, which potentially challenge the organisation’s productivity and survivability.

Based on the typology of Emery & Trist (1965), we construct a topology (Figure 1), using two main dimensions of the effect of environmental externalities to the organisational growth: constraining, and negative impact. We use the term “Stress” to describe and represent negative environmental externalities that constrain organisational growth and take the form of scarcity of available resources. On the other hand, we employ the term “Disturbance” to describe unpredictable, random, externalities that, when take place, have a significant negative impact on the organisational growth. Examples of that externalities include new disruptive technologies, new legislative rules, and societal changes, among others. For space considerations, we classify disturbances into two main categories: new technologies,

and risks, because new technologies have a positive, unrealised potential for the organisation, as opposed to risk which lack such a potential.

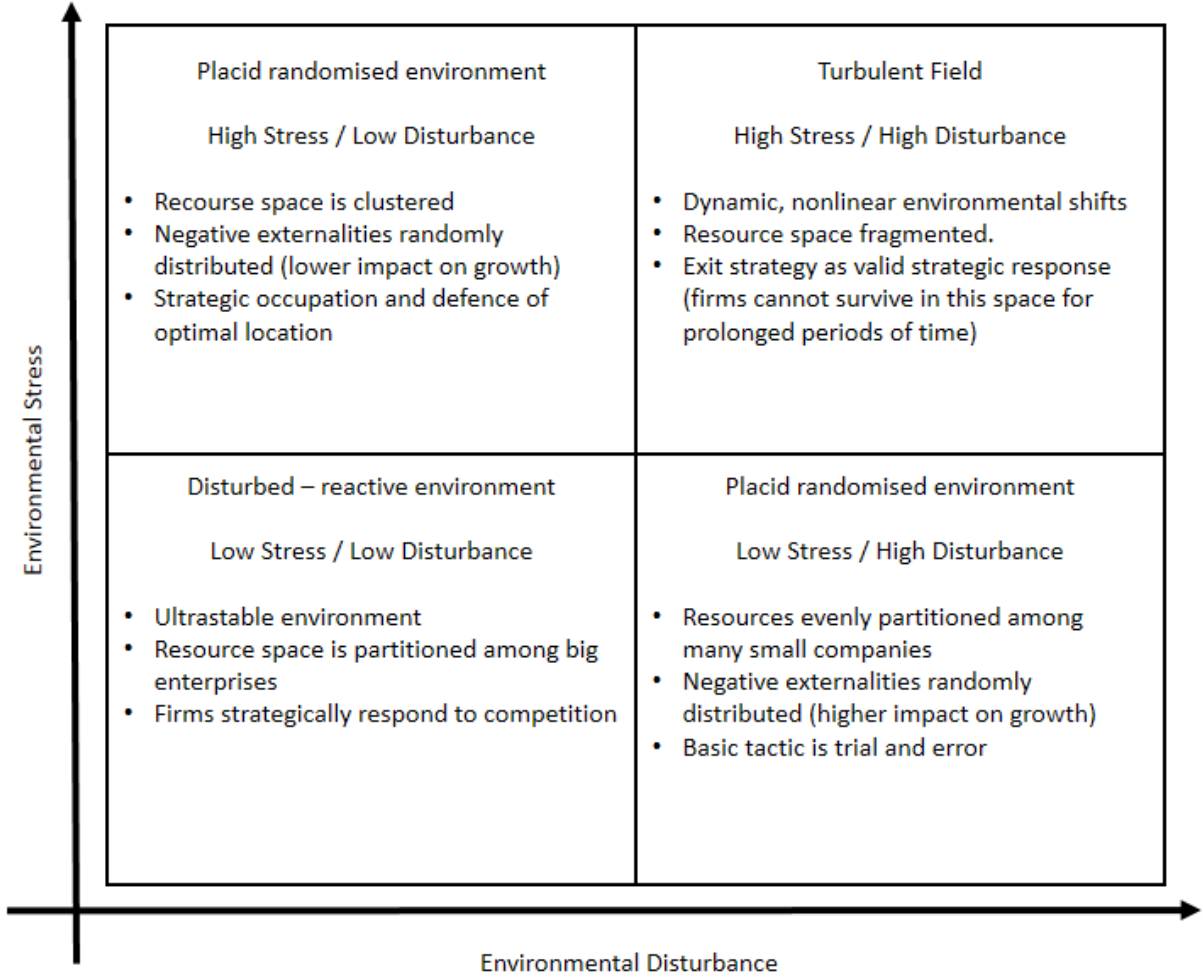

Figure 1: The environmental topology.

**5. Business Modelling**

However, the environmental uncertainty is perceived subjectively in the business world (Zott & Amit 2008). As a result, there is a reciprocal relationship between the environment and the organisation (Lengnick-Hall 2005). In this paper we focus on the emergent organisational change as a reaction to the environment (Emery & Trist 1965). For that purpose, following Demil & Lecocq (2010), we adopt an RCOV (Resource – Competencies – Organisation – Value proposition) point of view. Demil & Lecocq (2010) argue that organisational changes in terms of Business Model can be emergent and dependent on the environment. Penrose (1995) argues that organisations’ growth depends on its resources to fuel the value creation process.

The firm's knowledge of the resources and the technology to transform those into value propositions allows the firm to transition from an emergent state to a growing one, as a reaction to the environment's resources. Our approach is consistent with Demil & Lecocq (2010) and Penrose (1995) and move one step forward via an attempt to directly link and measure the BM's emergent resilience to the environmental shifts by using the resource space (Stress) and the technological regime (Disturbance) as the main dimensions of BM's resilience (Figure 1). To measure the BM's resilience, we attempt a decomposition of BM using the RCOV model suggested by Demil & Lecocq (2010).

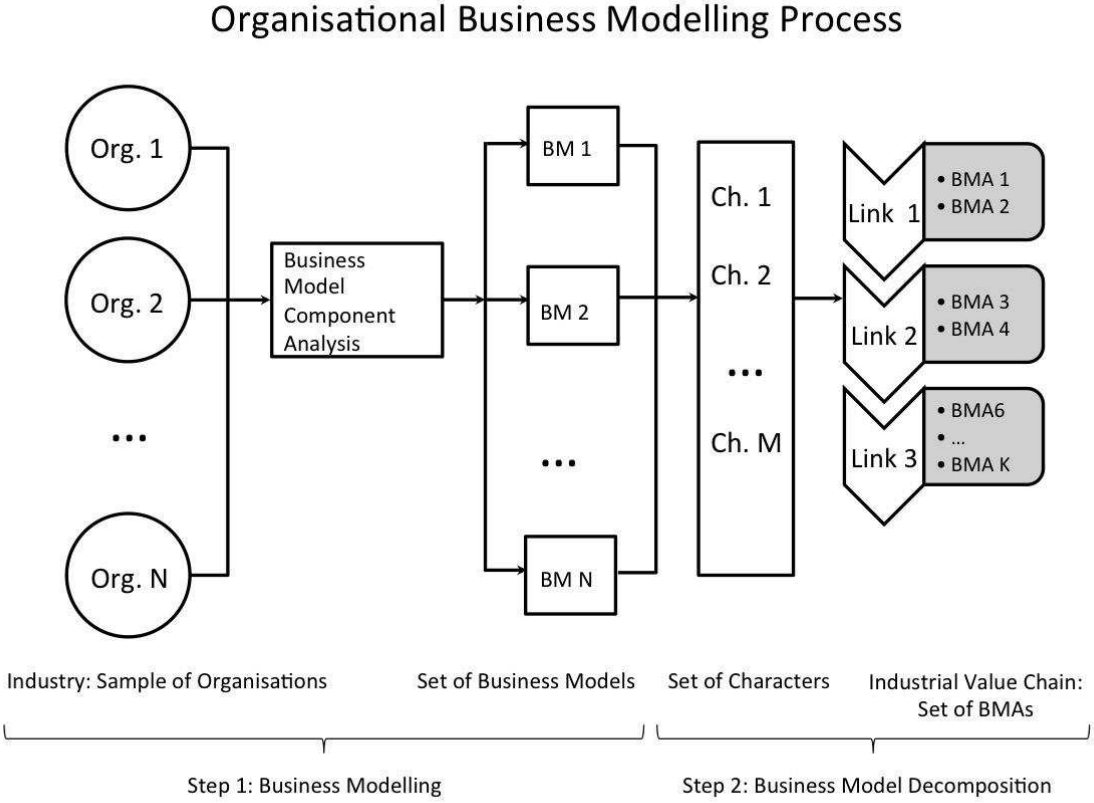

Figure 2: Business Modelling Process

RCOV BM framework consists of three main pillars: Resource and competencies, value propositions, and internal and external organisation. Resources and competencies (RC) are combined and valued to support the value proposition of the BM. Different value propositions (V) require different resources and competencies.

The value proposition may take the form of products or services, which determines the structure of costs and revenues (margin). On the other hand, those resources, and competencies, that are not within the explicit control of the BM are captured by the Organisation (O) dimension. The organisation dimension includes the value network that includes the external stakeholders, partners, customers etc. of the BM. Based on the RCOV framework, we attempt a gradual decomposition of the organisation's BM to components, and elements.

In this paper, we assume that every organisation is characterised by its corresponding BM. As a result we assume a one-to-one relationship between the organisation and its BM. This assumption does not contradict the argument that a BM, as a cognitive structure, transcends the physical boundaries of an organisation to capture processes and resources that are necessary for the value proposition but are beyond the explicit control of the firm. Based on this assumption, the first step of our analysis revolves around "translating" the organisational structure into its corresponding BM Components. We call this process business modelling (Figure 2). The identified BM components are characterised by a set of elementary units (or variables) that we call *Characters* (McCarthy et al. 2000). These value of the variables is used to determine the building blocks of the BMs' components.

The array of the BM elements, however, is not unbounded, but produces a finite number of organisational configurations (Meyer et al. 1993). Based on configurational theory, we attempt a rearrangement of the elements into Archetypes (Goumagias et al. 2014). Business Model Archetypes (BMAs) are organisational gestalts that focus on value creation according to the industrial value chain that they operate. They are aspects of the Type I BMs of Chesbrough (2007) typology which are undiversified BMs. We move one step forward and argue that the Archetypes are the building blocks of the industrial BM ecosystem.

We call the process of BMA construction as Business Model Decomposition. The process is based on identifying the organisational gestalts from the pool of elements provided by business modelling. To establish the necessary causality between the BMAs and the corresponding value chain link we employ an evolutionary based methodology, namely Cladistics Classification. Cladistics classification groups entities together based on how recently they share a common ancestor (phylogeny) .

It is an empirically driven taxonomy that stems from the biological school of systematics. It is based on historical event analysis and consequently circumvents the contingency theory to establish causality for the relationship among the classified entities because it identifies the most parsimonious routes of BM change. Via cladistics classification it is feasible to identify the constellation of the industrial BMAs, and describe their corresponding relationship based on how recently they share a common ancestor. A phylogenetic based classification (cladistics) is also consistent with the BM literature on evolutionary change of BM (Demil & Lecocq 2010; Baden-Fuller & Haefliger 2013; Baden-Fuller & Morgan 2010). A detailed description of Cladistics goes beyond the scope of the paper. However, there are studies that demonstrate its applicability and advantages within the organisational and BM context (McCarthy et al. 2000; Goumagias et al. 2014).

Focusing on historical event analysis as the basis of our suggested framework we aim for another advantage that would allow us to explore through time the relationship between environmental changes and the emergence of certain elements, and subsequently BMAs and BMs. This allows us to proceed in assigning a label for each element based on the source of its emergence as a reaction to environmental change: stress or disturbance, and consequently be able to measure the emergent resilience of the corresponding archetype and BM.

## **6. Measuring and contextualising Business model Resilience.**

Following BM decomposition as described by the second step shown in Figure 1, we are able to create three sets. Set  $\Omega$  contains a group of characters used as elements of constructing and describing BM components, as in BM component analysis. Set  $A$  contains the BMAs constructed by combining BM components. As a result, set  $A$  is a subset of set  $\Omega$  ( $A \subseteq \Omega$ ), and BMAs are both supersets of BM components and subsets of  $A$  ( $A_i \subseteq A \subseteq \Omega$ , where  $i \in \{1,2,\dots,M\}$  is the population of the BMAs). Therefore  $A_i \cap A_j = \emptyset$ , implying that a specific group of BM components, and consequently characters, may belong to more than one archetypes. A graphical representation of this process provided Figure 3:

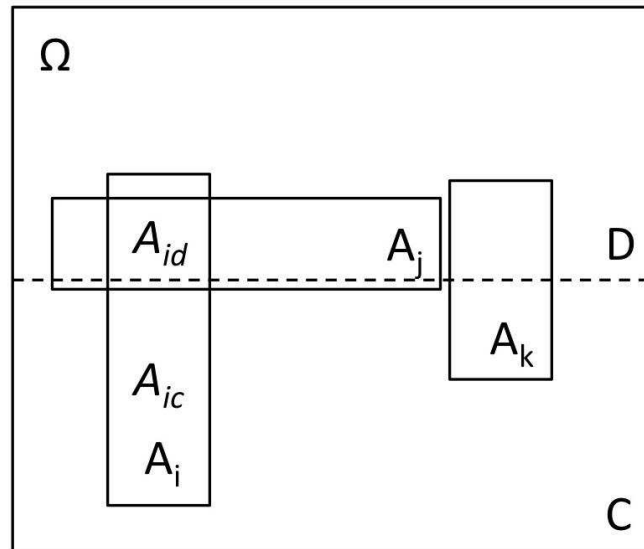

Figure 3: A geometric representation of the relationship among different levels of BM component analysis: Characters, BMAs, and the division of the environmental space into constraining and disturbing impact on BMAs' performance.

However, characters emerge in order to meet environmental challenges, and the impact of environmental challenges on BMs' performance divides the geometric space of characters into two mutually exclusive subsets:  $C \subseteq \Omega$  and  $D \subseteq \Omega$ , with  $C \cap D = \emptyset$  implying that a character can emerge as a reaction to a environmental constraint or disturbance, as shown in Figure 3. In certain cases, some the emergence of an element as a reaction to a stressful or a disturbant environmental shift may not be clear. In that case, we follow the internal decomposition of the character (McCarthy et al. 2000). Internal character decomposition suggest analysing the characters in terms of structure and identify the aspect that that corresponds to the stressful or disturbant shift, and split the character into two new character for consistency.

This environmental dichotomy helps to contextualize business modeling in terms of environmental impact, and also helps dividing the environmental geometric space into four areas. As a result, we use it to develop a typology and assign a position for each BMA on the map (Figure 1) according to the corresponding resilience, as described in Figure 4. In doing so, we assume that it is not possible for a BMA to operate within an environment the where its productivity and growth are equally constrained and disturbed. In addition, we assume that BMs cannot operate in a

highly competitive environment of low constraints and disturbance because, as we argued in Section 2, BMAs are not sufficiently diversified to take advantage of economies of scales possibly arising in that particular environment (Chesbrough 2007). As a result, we can identify three types of BMAs: *constraint oriented*, *disturbance oriented*, and *in-between*.

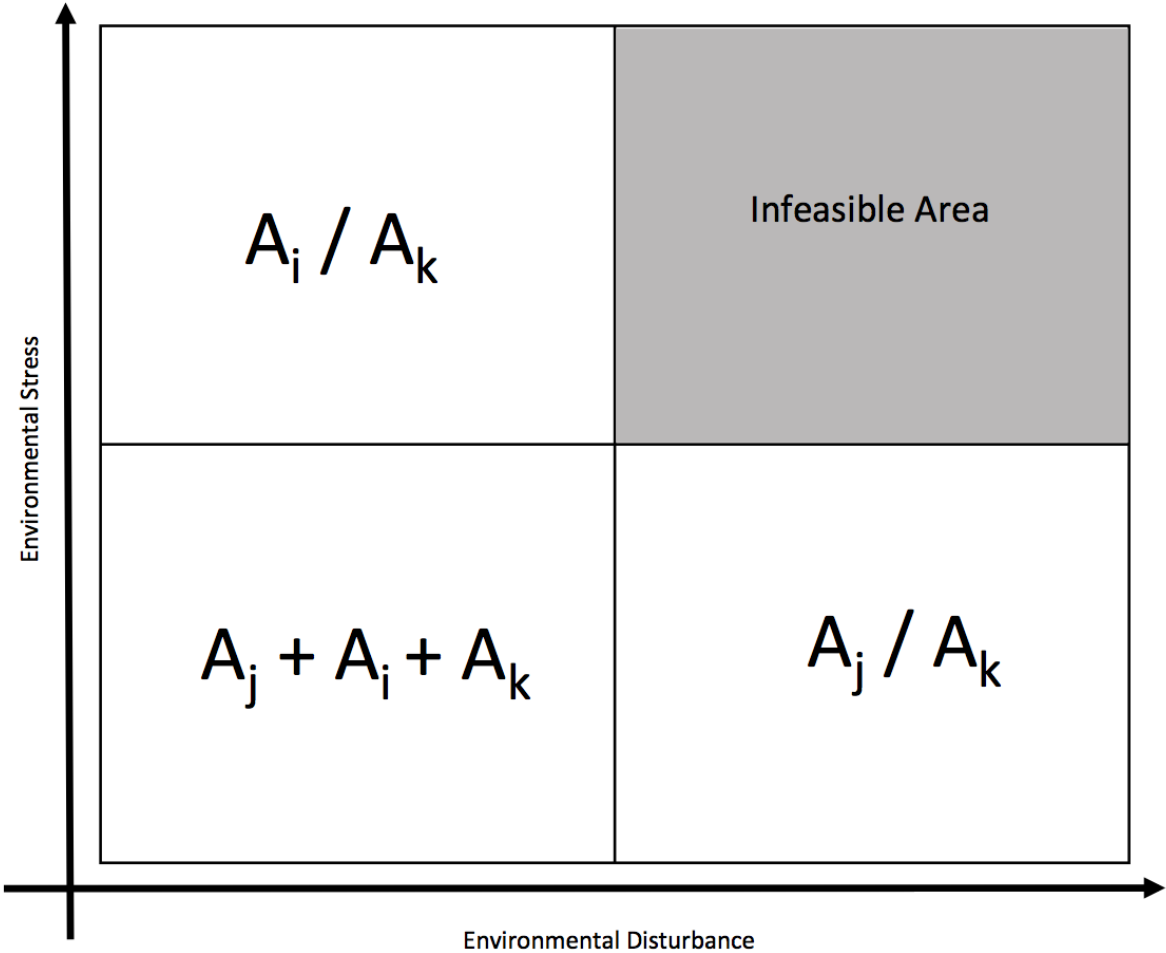

Figure 4: A two dimensional typology of BMAs according to the environmental impact on the Archetypes performance: constraining or disturbing.

With our analysis, we do not aim to measure the intensity of the environmental impact (whether constraining or disturbing). Instead, we aim to estimate the direction of environmental mitigation produced by BMAs. As BMA's  $A_i \in A$  are subsets of the character space  $\Omega$ , they consist of two mutually exclusive subsets: characters that emerged in reaction to a constraint  $A_{ic}$ , or in reaction to a disturbance  $A_{id}$ , with  $A_{ic} \cap A_{id} = \emptyset$ . Hence, we can argue that if  $|A_{id}| < |A_{ic}|$ , then the BMA is mostly a constraining mitigating archetype (Where  $|\cdot|$  is the Cardinality measure of the



corresponding Set). Conversely, if  $|A_{id}| > |A_{ic}|$ , then the BMA is mostly a disturbance oriented archetype. Finally if  $|A_{id}| = |A_{ic}|$ , then the BMA can be equally part of the two spaces.

The boundaries that are used to separate the four environmental spaces can be determined empirically using the BMAs. Assuming that several value proposition exist within a given link of the industrial value chain, and that environmental shift cause variations in BM structures that revolve around a given value proposition (Demil & Lecocq 2010), it is safe to argue that BMAs emerged to fit particular environmental textures. As a result, BMAs that operate in placid clustered environments would be characterized by increased number of stress-mitigating characters, compared to BMAs that evolved in placid randomized environments which would have increased number of disturbance mitigating characters. As a result, the boundaries of the framework we suggest could be an exercise of fitting them within the geometry of the environmental space. We elaborate further on that exercise in the next Section.

### **Case Study: The Biopharmaceuticals Industry**

In this section we attempt an application of the framework within the context of biopharmaceuticals industry. We draw empirical evidence from the brief history of the industry to perform a longitudinal historical analysis (Mamouni Limnios et al. 2014). We start our analysis via a narrative exploration of the industry's BM history (Teece 2010) and we capture the BMs' salient features using the RCOV framework (Demil & Lecocq 2010). Based on the RCOV, we construct the array of Characters that will be re-configured into BMAs, according to their corresponding value proposition (specific links of the industrial value chain).

The biopharmaceuticals industry is defined, according to the Organisation of Economic Cooperation and Development (OECD 1989), as the collective economic activities that, based on scientific and engineering principles, transform materials using biotechnology agents with a purpose to obtain products and service. The value propositions of the industry revolve around research and development of biologics-based solutions, diagnostic products, and bioinformatics (complementary assets). The service-based aspects of the industry's value propositions focus on technology licensing (manufacturing, and or research and development: Bigliardi et al. 2005).

The biotechnology industry is particularly appealing for our exercise because its relatively young age allows a more thorough investigation, hence limiting potential bias. Moreover, the biotech industry is dynamic, and technologically intensive, which is an influencing factor of business mode innovation, leading to increased diversity (Chesbrough 2007). In literature, the terms “biopharmaceuticals” and “biotech” are used interchangeably. For consistency purposes, we are going to use the term biotech in this paper.

Arguably, the first biotech firm was founded in 1976, called Genetech Inc. (Rutherford 2001). It was the first time in history that *restriction enzymes* were used to directly intervene in the DNA structure and allow mass production of recombinant DNA molecules using bacteria and other animals. During the 1980s, the biotech production revolved around recombinant insulin, human growth hormone, and interferon gamma. In terms of BMs, both Genetech in the States, and Biotech Plc. (the first European biotech company) were characterised by a vertically integrated BM (Research, Development, Mass manufacturing, and Sales and Marketing). This increased the companies' exposure to risks. Today, BMs have evolved to meet the market's needs via the emergence of start-ups and spinoffs based on licensing agreements and royalties as their main revenue streams.

The biotech sector's BM ecosystem evolved into three main types of BMs (Rutherford 2001; Willemstein et al. 2007): Service / Product, Platform, and Hybrid. The service BM focuses on contracted research of novel biotech solutions and technologies. The entry barriers in terms of financing are relatively low (Bigliardi et al. 2005) and develops informal network links with university researchers (Luukkonen 2005). On the other hand, Platform BMs focus on research and development of complementary assets in forms of platform technologies. Consequently, they rely on the wider applicability of the technology to create and sustain steady revenue streams in terms of contracting, and royalties (servitisation). Particularly in Europe, aiming for mitigating the lack of venture capitals available, this type of BM relies on a steady and consistent revenue stream to fuel profit generation retained for reinvestment. There are two subtypes of product development BMs, depending on the phase of the development process (3 phases). The first subtype of product BM focuses on Phase I and II, namely early development process, while the second subtype focuses on the third phase of development, or mass production. The first

subtype faces increased risk and challenges regarding sources of income. The hybrid BM, on the other hand is characterized by a vertical integration of the industrial value chain and combines several activities, and value propositions (Rutherford 2001). This type of BM focuses on out licensing product and platform technology to pharmaceutical, top-tier biotechnology companies, and at Phase III they engage in direct commercialisation. However, orphan patents and drug legislation can provide an alternative route of biosimilars production.

<b>RCOV Framework: List of Characters</b>					
<b>1 Value proposition</b>			<b>3 Organisation</b>		
Code	Character	Label	Code	Character	Label
1.1	R&D Biologics	D	3.1	Links with academia	D
1.2	R&D Diagnostics	D	3.2	Spinoffs and incubations	D
1.3	Bioinformatics	D	3.3	Parent company	D
1.4	Technology licensing	D	3.4	Innovation network	D
1.5	Complementary assets	D	3.5	Joint marketing and sales	S
1.6	Development support	S	3.6	Financial outsourcing	S
			3.7	In-house distribution	S
			3.8	3 <sup>rd</sup> party distribution	S
			3.9	Medical institutions	S
			3.10	Pharmacies	S
			3.11	B2B (general)	D
			3.12	Biotech firms (platform)	D
			3.13	Biopharmaceutical firms (product)	S
			3.14	Decision makers	S
<b>2 Resources and competencies</b>			<b>4 Revenue model and cost structure</b>		
2.1	In-house production	S	4.1	Royalties (product)	D
2.2	Development technology	D	4.2	Royalties (patent)	D
2.3	Private funds	D	4.3	Commercialisation	S
2.4	Private + public funds	S	4.4	Servitisation	S
2.5	Venture capitals	D			
2.6	Retained profits	S			
2.7	Patent development	D			
2.8	Expired patent acquisition	D			
2.9	In-house manufacturing	S			
2.10	Manufacturing outsourcing	D			
2.11	In-house marketing	S			
2.12	Marketing outsourcing	S			
2.13	Literature research	S			

Table 1: The list of characters grouped together based on the RCOV framework. Each character is assigned the label S if it stems from a historical stressful character

(lack of resource), or D if it stems from a disturbing environmental factor (technological, or risk).

The historical narrative of the biotech sector can be summarised in Table one. The variables are grouped based on the components of the RCOV framework (Figure 2), and they are coded accordingly using a 2-digit system. The first digit corresponds to the component that the character belongs to and the second corresponds to the character in ascending order. Coding is used for space considerations. Based on the historical analysis, each character is assigned with a label that informs on the type of the environmental impact on the emergence of that particular character. In case the character stems from environmental stressful factor is assigned S, while in the case of a disturbance, the letter D is assigned.

The rearrangement of the Characters in table 1, allows the identification of 9 BMAs based on the industrial value chain. Moreover, we present the resilience measure of each archetype. We use the term S-resilience to describe the number of characters from the set C (stressful characters) that belong to the corresponding BMA. D-resilience, respectively, measures the number of characters that stem from a disturbance (D set: Figure 3).

<b>BMA Name</b>	<b>List of character</b>	<b>Value chain link</b>	<b>S-Resilience</b>	<b>D-Resilience</b>
Entrepreneurial Spin-out	1.1 1.2 2.7 3.1 2.12 3.15 3.12 3.13 4.7 4.9 4.2 2.10 4.1 2.4 4.2	Research	4	11
In-house researching	1.1 1.2 2.7 3.1 2.12 3.15 3.12 3.13 4.7 4.9 4.2 2.10 4.1 2.4 2.6 3.3 4.2	Research	6	11
V-C Firm	1.1 1.2 2.7 3.1 2.12 3.15 3.12 3.13 4.7 4.9 4.2 2.10 4.1 2.4 2.5 4.8 4.2	Research	5	12
Strategic alliance	1.1 1.2 2.7 3.1 2.12 3.15 3.12 3.13 4.7 1.3 2.4 4.10 3.14 2.1 3.11 2.2 2.3 3.4 4.6	Development	6	13
Commercial strategic alliance	1.1 1.2 2.7 3.1 2.12 3.15 3.12 3.13 4.7 1.3 2.4 4.10 3.14 2.1 3.11 2.2 1.6 2.3 3.5 3.6	Development	9	11
Development	1.1 1.2 2.7 3.1 2.12 3.15 3.12 3.13 4.7 1.3 2.4 4.10 3.14 2.1 3.11 2.2 1.6 1.4 4.11 2.1 4.4	Development	10	11
Mass producer	1.1 1.2 2.7 3.1 2.12 3.15 3.12 3.13 4.7 1.3 2.4 4.10 3.14 2.1 3.11 2.2 1.6 1.4 4.11 2.1 4.4	Manufacturing	15	11

	3.7 3.8 4.3 3.9 3.10			
Patent acquirer	2.7 2.11 1.5 2.13	Sales	2	2
Biosimilars	2.7 2.11 1.5 2.13 2.8	Sales	2	3

Table 2: The list of the identified BMAs, their corresponding characters, and the value chain link they operate.

The two numbers, provide the coordinates to represent each archetype on the resilience topology. The BMA then, as role models, helps us create a reference point in order to benchmark against the industrial business models (Figure 4). Figure 4 depicts a topology of all the industrial biotech BMAs according to their S and D resilience (the two resilience dimensions). The BMAs, as role models (Baden-Fuller & Morgan 2010) are used to define the boundaries among the 4 types of environmental causal texture.

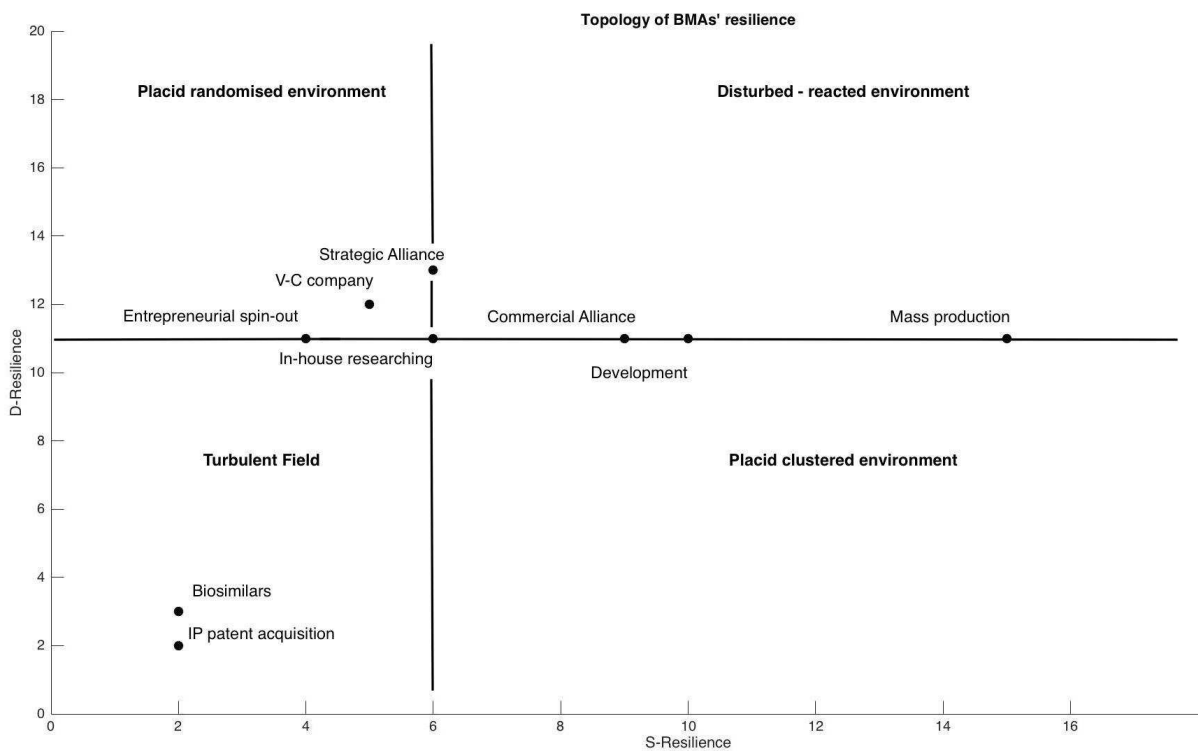

Figure 4: The resilience topology (S-resilience, D-resilience) of the biotech sector. The BMAs are depicted using S and D resilience as coordinates.

Figure 4 can allow to draw some insights on the biotech sector. Biotech companies followed 3 main evolutionary paths that face distinct environmental challenges. The research BMAs, face a rather disturbant environment. This can be mainly attributed

to the fact that the sector is highly technologically intensive sectors. Companies are called to deal with a significant number of potential disruptive technologies that constantly challenge the current status quo. On the other hand, the BMAs focusing on Development and Manufacturing of drugs, evolved to mitigate stressful factors that stem from lack of resources, given the high costs caused by constantly changing products development procedures. Finally, two archetypes are within the Turbulent field: IP acquisition and biosimilars. These two archetypes cannot be sustained independently. They can only exist as part of a diversified business model. However, they provide strategic alternatives to companies that aim to reinforce their resilience profile, particularly those that operate in the development and manufacturing parts of the industrial value chain.

## **7. Concluding Remarks**

In this paper, we argued that BMs as a cognitive structures do not obey to the traditional, historic event analysis of organizational theory that use birth, life and death of a given organization as proxies to explore and examine market selection mechanisms. Instead, BMs (either as models, architectures or recipes) cease to exist when becoming irrelevant to managers and organisations.

We assume that BMs consist of a set of elementary components (tacit, knowledge, activities, resources and networks), which are building blocks of BM components or characters. These characters emerge as a reaction to environmental changes, placing the environment at the centre of BM change. On the one hand, characters can be grouped according to two types of environment impact: constraining or disturbing. On the other hand, BM components are not combined randomly, but organised in function of the BM value proposition (value creation and capturing) into BMAs. These BMAs provide the narrative behind value creation and capturing on each given link of an industrial value chain.

By dividing the geometric environmental space based on the potential impact it might generate on the productivity and performance of BMs, and by using set theory to examine the direction of the resilience of BMAs towards the environmental changes, we can construct a typology of the BMAs according to their emergent resilience.

The conceptual framework suggested in this paper aims to contribute towards the theoretical discussion of BM change (emergent or deliberate), and to provide both academics and practitioners with a working prototype of capturing the salient features of emergent resilience in the domain of BMs. In addition, it aims to encourage further empirical analysis and investigation and further research on BM construction and dynamics, stimulating the study of causal relationships within the business environment. In particular, we believe that future research should focus on the dimension of deliberate resilience, as it emerges from reconfiguring the BM architecture via the rearrangement of BMAs within companies' BMs.

## **8. Acknowledgments**

We acknowledge the financial support from the EPSRC and ESRC Digital Economy Programme: NEMOG New Economic Models and Opportunities for Digital Games, grant number EP/K039857.

## **Bibliography**

- Annarelli, A. & Nonino, F., 2014. Strategic and operational management of organizational resilience: Current state of research and future directions. *Omega*, pp.1–18.
- Arthur, W., 1989. Competing technologies, increasing returns, and lock-in by historical events. *The economic journal*, 99(394), pp.116–131.
- Astley, W.G. & Van de Van, A., 1983. Central Perspectives and Debates in Organization Theory. *Administrative Science Quarterly*, 28(2), pp.245–273.
- Baden-Fuller, C. & Haefliger, S., 2013. Business models and technological innovation. *Long Range Planning*, 46(6), pp.419–426.
- Baden-Fuller, C. & Morgan, M.S., 2010. Business models as models. *Long Range Planning*, 43(2), pp.156–171.
- Bhamra, R., Dani, S. & Burnard, K., 2011. Resilience: the concept, a literature review and future directions. *International Journal of Production Research*, 49(18), pp.5375–5393.

- Bigliardi, B., Nosella, A. & Verbano, C., 2005. Business models in Italian biotechnology industry: a quantitative analysis. *Technovation*, 25(11), pp.1299–1306.
- Boisot, M. & Child, J., 1999. Organizations as adaptive systems in complex environments: The case of China. *Organization Science*, 10(3), pp.237–252.
- Brand, F., 2009. Critical natural capital revisited: Ecological resilience and sustainable development. *Ecological Economics*, 68(3), pp.605–612.
- Chesbrough, H., 2007. Business model innovation: it's not just about technology anymore. *Strategy & leadership*, 35(6), pp.12–17.
- Demil, B. & Lecocq, X., 2010. Business model evolution: in search of dynamic consistency. *Long Range Planning*, 43(2-3), pp.227–246.
- Derissen, S., Quaas, M.F. & Baumgartner, S., 2011. The relationship between resilience and sustainability of ecological-economic systems. *Ecological Economics*, 70(6), pp.1121–1128.
- DiMaggio, P. & Powell, W., 1983. The Iron Cage Revisited. *American Sociological Review*, 48, pp.147–160.
- Dosi, G., 2000. *Innovation, organization and economic dynamics: selected essays* E. Elgar, ed., Cheltenham.
- Dosi, G. & Marengo, L., 2007. Perspective-on the evolutionary and behavioral theories of organizations: A tentative roadmap. *Organization Science*, 18(3), pp.491–502.
- Emery, F. & Trist, E., 1965. The causal texture of organizational environments. *Human relations*.
- Geels, F.W., 2014. Reconceptualising the co-evolution of firms-in-industries and their environments: Developing an inter-disciplinary Triple Embeddedness Framework. *Research Policy*, 43(2), pp.261–277.
- Goumagias, N. et al., 2014. A Phylogenetic Classification of the Video-game Industry's Business Model Ecosystem. In *Proceedings of the 15th*



*IFIP/SOCOLNET Working Conference on Virtual enterprises, PRO-VE 2014*. pp. 285–295.

Holland, J.H., 1975. *Adaptation in Natural and Artificial Systems*,

Holling, C.S., 1973a. Resilience and Stability of Ecological Systems. *Annual Review of Ecology and Systematics*, 4(1), pp.1–23.

Holling, C.S., 1973b. Resilience and Stability of Ecological Systems. *Annual Review of Ecology and Systematics*, 4(1), pp.1–23.

Hoskisson, R.E. et al., 1999. Theory and research in strategic management: Swings of a pendulum. *Journal of Management*, 25(3), pp.417–456.

Iakovou, E., Vlachos, D. & Xanthopoulos, A., 2007. An analytical methodological framework for the optimal design of resilient supply chains. *International Journal of Logistics Economics and Globalisation*, 1(1), p.1.

Klibi, W. & Martel, A., 2012. Modeling approaches for the design of resilient supply networks under disruptions. *International Journal of Production Economics*, 135(2), pp.882–898.

Lamberg, J.A. & Parvinen, P., 2003. The river metaphor for strategic management. *European Management Journal*, 21(5), pp.549–557.

Lengnick-Hall, C.A., 2005. Adaptive Fit Versus Robust Transformation: How Organizations Respond to Environmental Change. *Journal of Management*, 31(5), pp.738–757.

Lengnick-Hall, C.A. & Wolff, J.A., 1999. Similarities and contradictions in the core logic of three strategy research streams. *Strategic Management Journal*, 20(12), pp.1109–1132.

Levinthal, D.A., 1991. Organizational Adaptation and Environmental Selection-Interrelated Processes of Change. *Organization Science*, 2(1), pp.140–145.

Lewin, A. & Volberda, H., 2003. Beyond adaptation-selection research: organizing self-renewal in co-evolving environments. *Journal of management studies*, 40(8), pp.2109–2110.

- Luukkonen, T., 2005. Variability in organisational forms of biotechnology firms. *Research Policy*, 34(4), pp.555–570.
- Mallak, L., 1998. Measuring resilience in health care provider organizations. *Health manpower management*, 24(4-5), pp.148–152.
- Mamouni Limnios, E.A. et al., 2014. The resilience architecture framework: Four organizational archetypes. *European Management Journal*, 32(1), pp.104–116.
- McCarthy, I. et al., 2000. Organisational diversity, evolution and cladistic classifications. *Omega*, 28(1), pp.77–95.
- Meyer, A.D., Tsui, A.S. & Hinings, C.R., 1993. Configurational approaches to organizational analysis. *Academy of Management Journal*, 36(6), pp.1175–1195.
- Mintzberg, H. & Waters, J., 1985. Of strategies, deliberate, and emergent. *Strategic Management Journal*, 6(3), pp.257–272.
- Nelson, R.R. & Winter, S.G., 1982. *An evolutionary theory of economic change*,
- OECD, 1989. *Biotechnology: Economic and wider impact*,
- Osterwalder, A. & Pigneur, Y., 2010. *Business Model Generation: A Handbook For Visionaries, Game Changers, And Challengers* Author: Alexander Osterwalder, Yves, Wiley.
- Penrose, E., 1995. *The Theory of the Growth of the Firm*,
- Rose, A., 2004. Defining and measuring economic resilience to disasters. *Disaster Prevention and Management*, 13(4), pp.307–314.
- Russell, H., 2015. Volkswagen: The scandal explained. *BBC*.
- Rutherford, J.F. and J., 2001. Business models and investment trends in the biotechnology industry in Europe. *Journal of Commercial*, 8, pp.191–199.
- Scarbrough, H., 1998. Path(ological) Dependency? Core Competencies from an Organizational Perspective. *British Journal of Management*, 9(3), pp.219–232.
- Schuster, P., 1996. How complexity arises in evolution? *Complexity*, 2, pp.22–29.

- Sosna, M., Treviño-Rodríguez, R.N. & Velamuri, S.R., 2010. Business model innovation through trial-and-error learning: The Naturhouse case. *Long range planning*, 43(2), pp.383–407.
- Suchman, M.C., 1995. Managing Legitimacy: Strategic and Institutional Approaches. *Academy of Management Review*, 20(3), pp.571–610.
- Sydow, J., Schreyögg, G. & Koch, J., 2009. Organizational path dependence: Opening the black box. *Academy of Management Review*, 34(4), pp.689–709.
- Teece, D.J., 2010. Business models, business strategy and innovation. *Long range planning*, 43(2), pp.172–194.
- Varela, F.J., Thompson, E. & Rosch, E., 1991. The Embodied Mind: Cognitive Science and Human Experience. *An International Journal of Complexity and*, p.328.
- Weber, M., 1964. *The theory of social and economic organization*, New York: Free Press.
- Weick, K.E., 1979. The social psychology of organizing. *Administrative Science Quarterly*, 2, p.294.
- Willemstein, L., van der Valk, T. & Meeus, M.T.H., 2007. Dynamics in business models: An empirical analysis of medical biotechnology firms in the Netherlands. *Technovation*, 27(4), pp.221–232.
- Wirtz, B.W. et al., 2015. Business Models: Origin, Development and Future Research Perspectives. *Long Range Planning*, In Press.
- Zott, C. & Amit, R., 2008. The fit between product market strategy and business model: implications for firm performance. *Strategic Management Journal*, 29(1), pp.1–26.
- Zott, C., Amit, R. & Massa, L., 2011. The business model: recent developments and future research. *Journal of Management*, 37(4), pp.1019–1042.